

WAT-1100MBD

OSD User's Manual

Rev. 1.10

Watec Co., Ltd.

2019/12/6

Change History

Rev. No.	Date	Changes	Remarks
1.00	2016/9/2		Initial Release
1.10	2019/12/6	The description of these chapter was modified 2.OSD Menu Operation Fig. How to Connect Controller 5.UART communication was added Description correction	

【Contents】

1.	Introduction	5
2.	OSD Menu Operation	6
3.	MAIN MENU/SETUP MENU	8
3.1	OSD Menu	8
3.2	Save Settings(SAVE ALL)	8
3.3	Lens Settings(LENS)	9
3.3.1	DC Iris Lens Setting(LENS)	9
3.3.1.1	DC Iris Lens Control Mode(MODE)	10
3.3.1.2	DC Iris Lens Control Speed(SPEED)	11
3.4	Shutter/Gain Settings	12
3.4.1	Automatic Exposure Control(AUTO)	12
3.4.1.1	Shutter Speed(SHUTTER)	12
3.4.1.2	Brightness Settings, High Luminance Side(AE LEVEL)	13
3.4.1.3	Auto Gain Control(AGC)	13
3.4.1.4	Brightness Settings, Low Luminance Side ((AE LEVEL)	14
3.4.2	Manual Exposure Control(MANUAL)	15
3.4.2.1	Shutter Speed (SHUTTER)	15
3.4.2.2	Gain Value Settings(AGC)	15
3.5	White Balance(WHITE BAL)	16
3.5.1	Auto Trace White Balance(ATW)	17
3.5.2	Push White Balance(PUSH)	17
3.5.3	Preset White Balance(USRE1 5100K/USER2 6300K)	18
3.5.4	Manual White Balance(MANUAL)	19
3.5.5	Push Lock White Balance(PUSH LOCK)	20
3.6	Back Light Compensation (BACKLIGHT)	21
3.7	Picture Adjust(PICT ADJUST)	22
3.7.1	Image Flip(FLIP)	22
3.7.2	Brightness(BRIGHTNESS)	22
3.7.3	Contrast(CONTRAST)	23
3.7.4	Edge Enhancement(SHARPNESS)	23
3.7.5	Chroma Settings(HUE,COLOR GAIN)	24
3.8	Defog(DEFOG)	25
3.9	Wide Dynamic Range / Tone Correction (WDR / ATR)	26
3.9.1	Adaptive Tone-Curve Reproduction (ATR)	27
3.9.2	Wide Dynamic Range (WDR)	28
3.10	Day & Night function (DAY/NIGHT)	29
3.11	IR LED Control(IR LED)	29
3.12	Noise Reduction(DNR)	30
3.13	Privacy Mask(PRIVACY)	31

<u>3.14</u>	CAMERA ID Setting(CAMERA ID) ······	34
<u>3.15</u>	LANGUAGE ······	38
<u>3.16</u>	Factory Reset(CAMERA RESET) ······	38
<u>3.17</u>	EXIT MENU(EXIT) ······	39
4.	OSD Menu Tree ······	40
5.	UART communication ······	47
<u>5.1</u>	Connection and electrical characteristics of communication terminals ······	47
<u>5.2</u>	Communication specification ······	48
<u>5.3</u>	Packet configuration ······	49
	Communication command simplified table ······	50

1. Introduction

- The WAT-1100MBD user's manual describes the functions and the adjustment methods using the On Screen Display (OSD).
- When the settings of the WAT-1100MBD is changed according to the WAT-1100MBD user's manual, check to see that the operation and the effects of the changes made to the camera are acceptable.
- The WAT-1100MBD user's manual is subject to change by design and the specifications of the product without notice.
- The copyright of the WAT-1100MBD user's manual shall belong to Watec Co., Ltd.
Copying in whole or in part without the authorization of the holders permission is prohibited.

2.OSD MENU OPERATION

The functions and parameter settings of WAT-1100MBD can be changed by OSD(On Screen Display).
Operate OSD with the controller.



Controller Overview

- a)When using the controller,vertically insert the connector fully until it clicks.
- b)When disconnecting the controller, pull the connector while pinching the Lock.

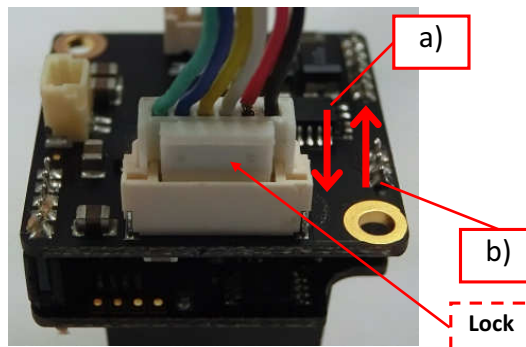

How to Connect Controller

The controller has 5 buttons, UP/DOWN/LEFT/RIGHT/ENTER.



The operation portion of the Controller

Use 5 buttons above to operate the OSD menu.

1)UP/2)DOWN : Mainly to move the cursor up and down to select an item on the lists on the OSD menu.

3)LEFT/4)RIGHT : Mainly to adjust and change the functions on each list on the OSD menu.

5)ENTER : Mainly to execute the selected list and function on the OSD menu.

The symbol "\leftarrow" will be on some lists on the OSD menu to indicate that there are sub menus or selectable options by pressing 5)Enter.

Please refer to the following model operation pictures on the basic controller usage.

The below picture shows the OSD operation when WHITE BAL(ATW) is selected as the default setting.



Switching the Menu

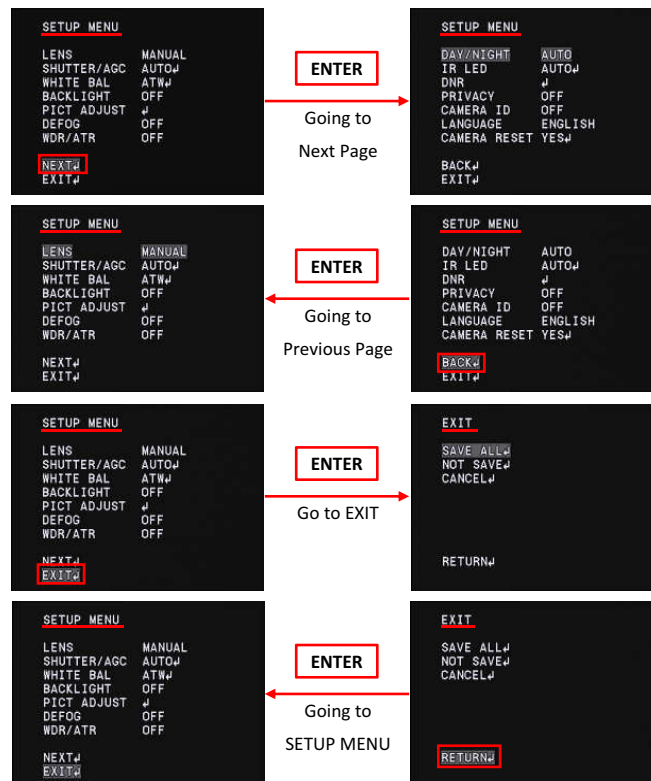

* From the next page, each button is written as follows.

- 1)UP key is written as "UP"
- 2)DOWN key is written as "DOWN"
- 3)LEFT key is written as "LEFT"
- 4)RIGHT key is written as "RIGHT"
- 5)ENTER key is written as "ENTER"

3. MAIN MENU/SETUP MENU

3.1 OSD Menu

SETUP menu will appear on the screen when pressing ENTER,

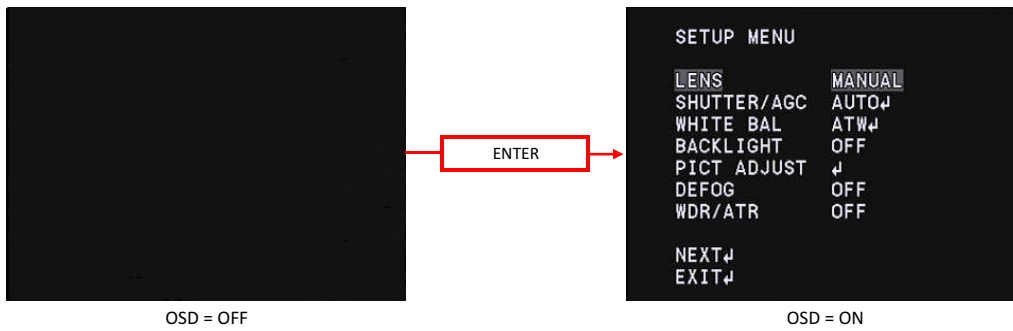

Move the cursor to EXIT with UP/DOWN buttons and press the ENTER to display the EXIT page.

OSD Menu is consist of 3 pages (SETUP MENU1/2-2/2 and EXIT).



3.2 Save settings (SAVE ALL)

Saving (SAVE ALL) the changes in camera settings. After changing camera settings, you can save the changed set values by executing SAVE ALL on the EXIT page. Move the cursor to SAVE ALL with UP / DOWN / LEFT / RIGHT and press ENTER to save the set value.

The saved settings are kept even after the camera is powered off.

*Please note that when you turn off the power without saving the setting values after changing the setting or execute CANCEL on the EXIT page, the changed setting will not be saved.

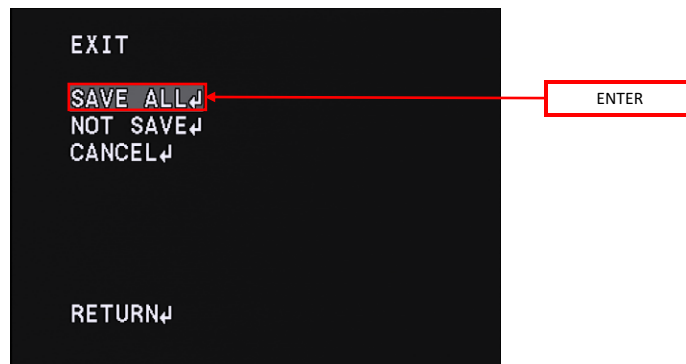

3.3 Lens Settings (LENS)

Change the lens setting according to the lens to be used. Move the cursor to LENS with UP/DOWN and use the LEFT/RIGHT to switch MANUAL and DC.

Default : MANUAL

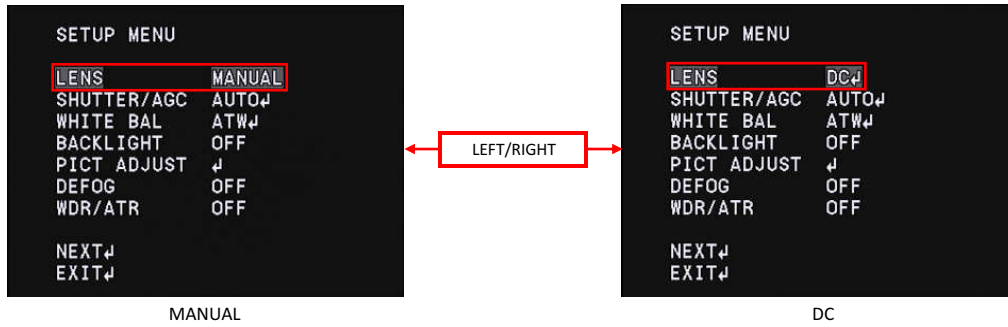

LENS	OPERATION
MANUAL	Select this mode when using a manual iris lens.
DC	Select this mode when using a DC iris lens.

*When you select DC in the LENS setting while using a manual lens, ordinary exposure control may not be available. Please change the LENS setting according to the lens to be used.

3.3.1 DC Iris Lens Setting (LENS)

Display the setting menu of the DC iris lens. Move the cursor to LENS and use the LEFT/RIGHT to select DC.

After selecting DC, press ENTER to display the LENS menu. Move the cursor up and down and adjust items with LEFT/RIGHT.

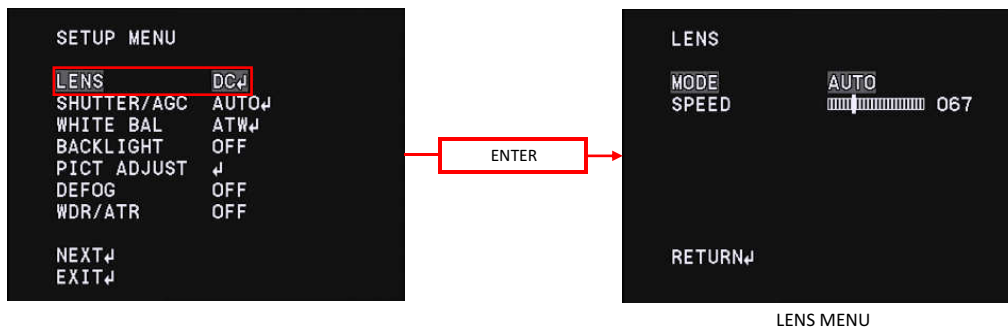

3.3.1.1 DC Iris Lens Control Mode (MODE)

Set the DC iris lens control mode (MODE). Use LEFT/RIGHT to select the MODE (lens aperture control)

Default : AUTO



MODE	OPERATION
AUTO	Control the lens aperture automatically. *For ordinary imaging, use AUTO mode.
OPEN	Open the lens aperture fully.
CLOSE	Close the lens aperture fully.

* This function will be the following control state by combining with SHUTTER/AGC of "3.4 SHUTTER /AGC setting(SHUTTER / AGC)"

Lens in use	SHUTTER/AGC	(LENS) MODE	OPERATION
DC Iris lens	AUTO	AUTO	Control the lens aperture automatically. *AUTO is recommended for using DC iris lens.
		OPEN	Open the lens aperture fully.
		CLOSE	Close the lens aperture fully.
	MANUAL	AUTO	Controls the lens aperture automatically.
		OPEN	Open the lens aperture fully.
		CLOSE	Close the lens aperture fully.

3.3.1.2 DC Iris Lens Iris Control Speed(SPEED)

Set the lens aperture control speed of auto iris lens(SPEED). Use LEFT/RIGHT to adjust the control speed of the lens aperture by moving the cursor.

Default : 67

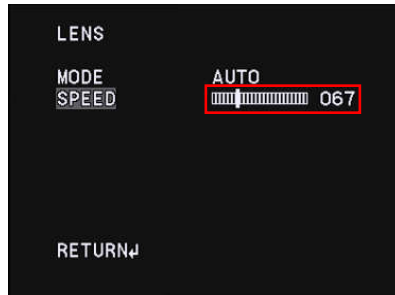

SPEED	OPERATION
000-255	<p>The smaller the set value, the slower the control speed, and the larger the set value, the faster the control speed.</p> <p>*When the set value is too large, the control speed will be faster, but it will cause hunting and overshoot. And please note that when the set value is too small, the operation will be delayed and it may stop.</p>

ODC iris lens adjustment procedures

When mounting the DC iris lens, adjust the lens aperture according to the following procedures.

The procedures for adjusting the DC iris lens is as follows.

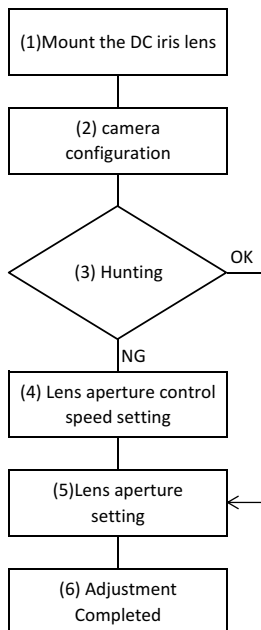

- (1) Mount the DC iris lens to the 1100MBD
- (2) Set the OSD settings as follows;
 - Set 『3.3 Lens setting (LENS)』 settings to DC
 - Set 『3.4 Shutter / gain setting (SHUTTER / AGC)』 settings to AUTO.
 - Set 『3.4.1.1 Shutter speed (SHUT)』 settings to DC IRIS.
- (3) When hunting occurs in which the screen continually brightens or darkens in the actual imaging environment, proceed to step(4). When you get the image properly, please proceed to step(5).
- (4) When hunting occurs, the control speed of the lens aperture might be too fast, reduce the set value of 『3.3.1.2 auto iris lens aperture control speed (SPEED)』 until the hunting stops.
- (5) Adjust the lens aperture. Adjust the lens aperture with 『3.4.1.2 Brightness Setting (AE LEVEL)』 . Adjust 『3.4.1.2 Brightness Setting (AE LEVEL)』 to optimize brightness while checking the monitor.
- (6) The adjustment is completed. Save the setting.

3.4 Shutter/Gain Settings(SHUTTER/AGC)

Set the exposure control. There are two modes of exposure control: the automatic exposure control (AUTO) and the manual exposure control (MANUAL). When AUTO is selected, shutter speed and gain are automatically controlled according to the imaging environment. When MANUAL is selected, shutter speed and gain can be set to arbitrary fixed values. Move the cursor to SHUTTER/AGC with UP/DOWN and use the LEFT/RIGHT to select AUTO or MANUAL. After selecting the mode, press ENTER to open each advanced setting sub menu.

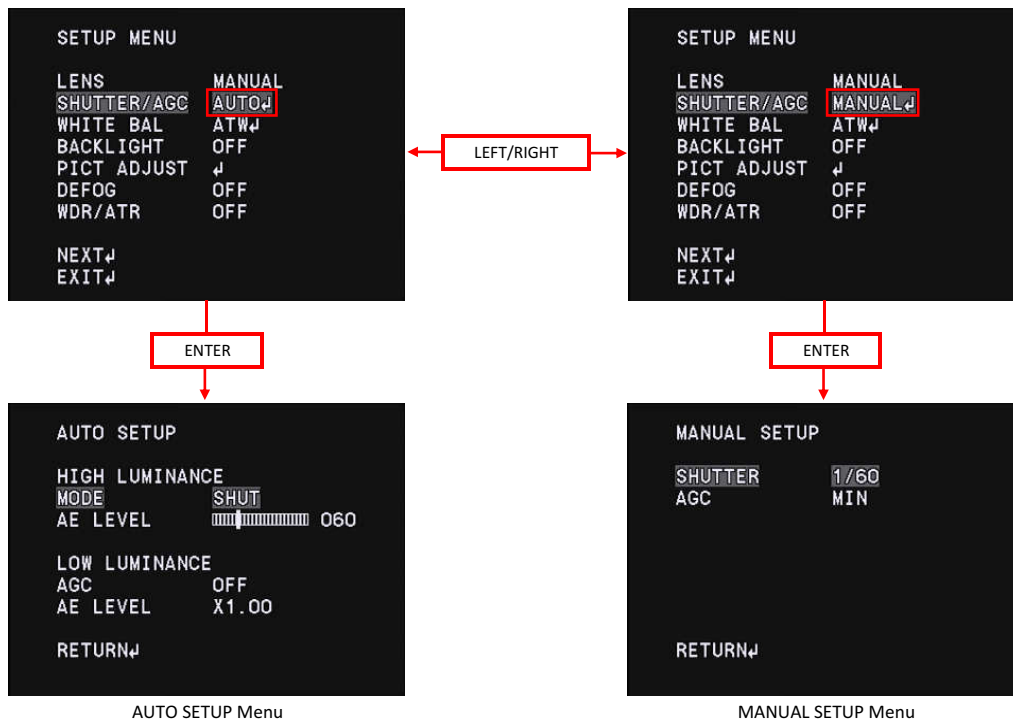

3.4.1 Automatic exposure control(AUTO)

3.4.1.1 Shutter Speed(SHUTTER)

Set the shutter speed (SHUTTER). Use the LEFT/RIGHT to select the shutter mode.

*Default : SHUT

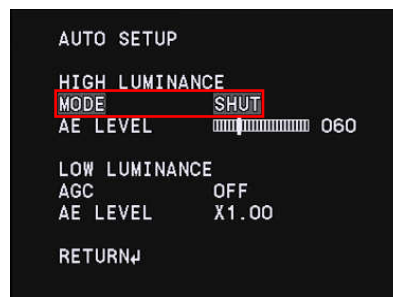

* In this function, selectable MODE defers by combining with LENS setting of [3.3 DC iris lens control setting (LENS)]. When the LENS setting is MANUAL, the selectable MODE is only SHUT. When the LENS setting is DC, select from either SHUT + DC IRIS or DC IRIS.

LENS	SHUTTER/AGC	MODE	OPERATION
MANUAL	AUTO	SHUT	Automatic exposure control by electric iris. Depending on the brightness of the shooting object, exposure will be controlled within the range of 1/60s(1/50s) to 1/100000s for getting the appropriate brightness. *(1/50s) : Default in PAL
DC	AUTO	SHUT+DC IRIS	Automatic exposure control by combining electric iris and DC iris. This mode uses electric iris preferentially and when it is still too bright, it will controlled by DC iris lens.
		DC IRIS	Automatic exposure control by DC iris. The exposure is only controlled with aperture of DC iris lens. *Electric iris does not operate in this mode.

3.4.1.2 Brightness settings, high luminance side(AE LEVEL)

Set the brightness in the screen (AE LEVEL). Use the LEFT / RIGHT to adjust the brightness.

*Default: Vary depending on the fine adjustment at factory

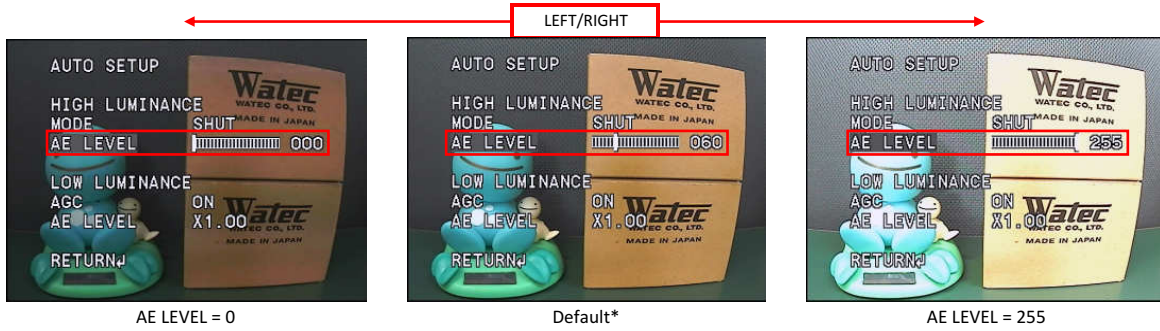

SHUTTER/AGC	AE LEVEL (HIGH LUMINANCE)	OPERATION
AUTO	0—255	Brightness can be set within the range of 0 (dark) -255 (bright). *When the auto iris lens is mounted, we will use the AE LEVEL to adjustment the lens aperture. For the details, see the auto iris lens adjustment procedures in 『3.3.2 Auto iris lens aperture control speed (SPEED)』

3.4.1.3 Auto Gain Control(AGC)

Set the auto gain control setting (AGC). Gain controls exposure at low luminance when electric shutter and DC Iris lens could not achieve the full exposure. Use the LEFT / RIGHT to select AGC ON or OFF.

*Default : ON

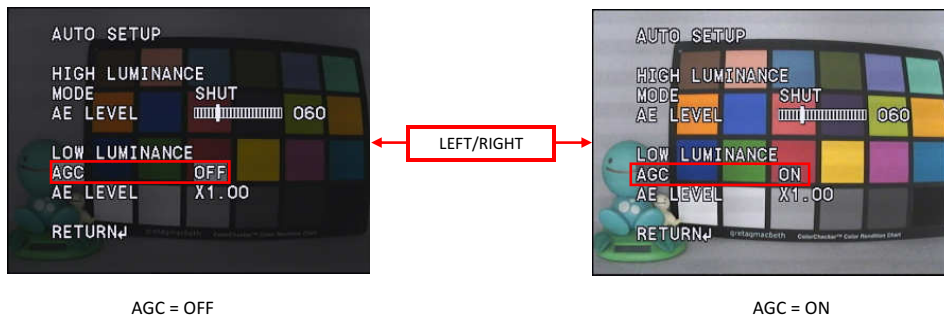

SHUTTER/AGC	AGC	OPERATION
AUTO	OFF	Exposure control at low luminance does not operate.
	ON	Automatic exposure control with gain at low luminance. *Gain range is 0 to 54 dB.

3.4.1.4 Brightness Settings, Low Luminance Side (AE LEVEL)

Set the brightness of exposure control at low luminance side(AE LEVEL) . Apart from 『3.4.1.2 Brightness Adjustment (AE LEVEL)』, the brightness at the time of gain operation can be set independently. For dark subjects, you could reduce the noise instead of darkening the image.

Use the LEFT / RIGHT to select from x0.25, x0.5, x0.75, x1.0.

*Default : x1.0

OAGC Operation

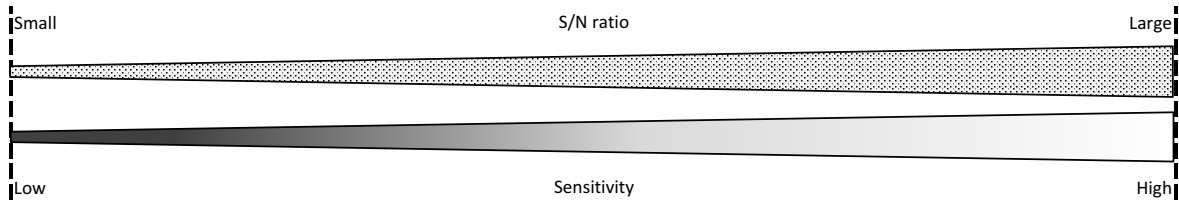
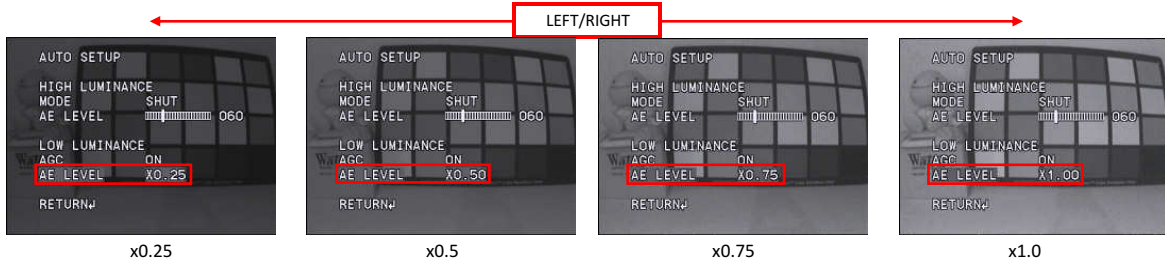

SHUTTER/AGC	AE LEVEL (LOW LUMINANCE)	OPERATION
AUTO	x0.25	The lower the value, the lower the sensitivity, the S/N ratio improves instead.
	x0.5	The higher the value, the lower the S/N ratio, the sensitivity improves instead.
	x0.75	
	x1.0	

3.4.2 Manual Exposure Control(MANUAL)

3.4.2.1 Shutter Speed (SHUTTER)

Set the shutter speed (SHUTTER) settings. Use the LEFT/RIGHT to select the shutter speed.

SHUTTER/AGC	MODE	OPERATION
MANUAL	SHUT	Selectable shutter speed : 1/60s(1/50s), 1/100s,1/120s, 1/125s, 1/250s, 1/500s, 1/1000s, 1/2000s, 1/4000s, 1/8000s, 1/10000s, 1/20000s, 1/50000s, 1/100000s *(1/50s) : PAL setting *Default : 1/60s(1/50s)

3.4.2.2 Gain value settings (AGC)

Set the gain value (AGC) settings. Use the LEFT/RIGHT to set the gain value.

*Default : MIN (0dB)

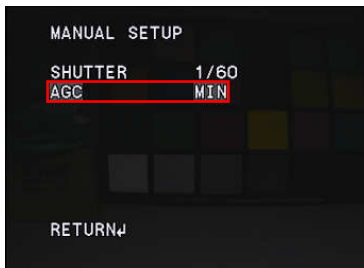

AGC = MIN (0dB)



AGC = 30dB

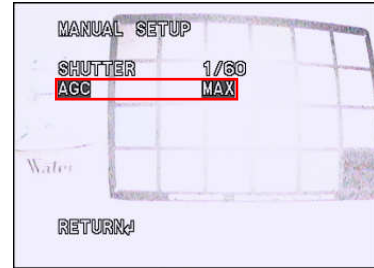

AGC = MAX (54dB)

SHUTTER/AGC	AGC	OPERATION
MANUAL	MIN—MAX	Fix the gain to an arbitrary value regardless of the brightness of the subject. The setting value can be selected from 18dB, 24dB, 30dB, 36dB, 42dB, 48dB, MAX(54dB). The higher the setting value, the brighter the image. The smaller the setting value, the darker the image.

3.5 White Balance(WHITE BAL)

Set the white balance (WHITE BAL) settings. This function is to correct white colored subjects to be shown as white under the illumination environment of various color temperatures . Use the LEFT / RIGHT to select the WHITE BAL from ATW, PUSH, USER1, USER2, MANUAL, PUSH LOCK.

*Default : ATW

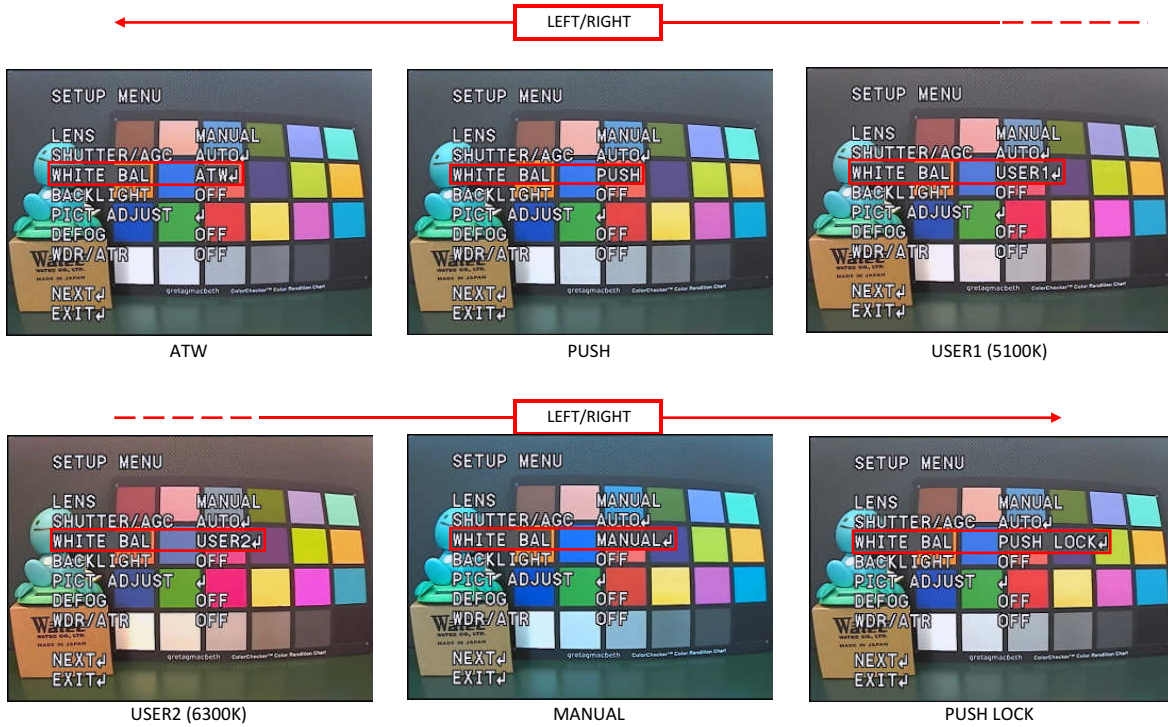

WB	OPERATION
ATW	ATW automatically controls the white balance and maintains color reproducibility by following the change in surrounding color temperature. Pull-in range is set in advance, it controls only when the surrounding color temperatures judged to be within the pull-in frame. By setting the pull-in frame, deterioration of color reproduction can be reduced without taking in pull-in operation in imaging scenes where monochrome occupies a large proportion in the screen.
PUSH	PUSH controls the white balance irrespective of subject conditions. Since the pull-in control always operates regardless of the preset pull-in range, the pull-in operates in a wider color temperature range than ATW, but the pull-in control operates even in the imaging scene where monochrome occupies a large proportion on the screen and color reproduction may be impaired.
PRESET	For the preset white balance, you can select the white balance correction value from the predetermined color temperature of USER 1 (5100 K) or USER 2 (6300K). It is effective if the color temperature of illumination to be used is known beforehand. USER1 (5100K) : (Fluorescent mode 2) Correct and fix the white balance based on the white under the lighting environment close to the bluish fluorescent light and fix it. USER2 (6300K) : (Sunlight mode) Correct and fix the white balance based on white under the lighting environment close to sunlight and fix it. The correction value of each preset white balance can be changed arbitrarily and respectively. When it is necessary to change, adjust the set value according to the usage environment.
MANUAL	MANUAL corrects the white balance with arbitrary setting values. Adjust the setting according to the usage environment.
PUSH LOCK	While pressing the ENTER, PUSH LOCK corrects the white balance according to the color temperature under the use environment and fixes the operation with the white balance correction amount at that moment of the Enter is released. Since it matches the actual lighting, it can correct accurately even if the color temperature is unknown.

3.5.1 Auto Trace White Balance(ATW)

ATW maintains color reproducibility even when the color temperature of the light source changes.

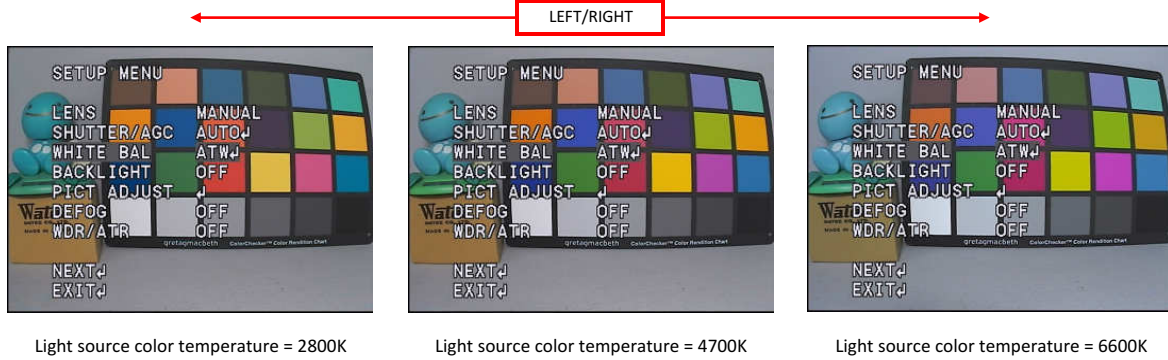

When ATW is selected, press the ENTER to display the WHITE BAL menu. Move the cursor up or down with the UP / DOWN and use the LEFT / RIGHT to adjust items.

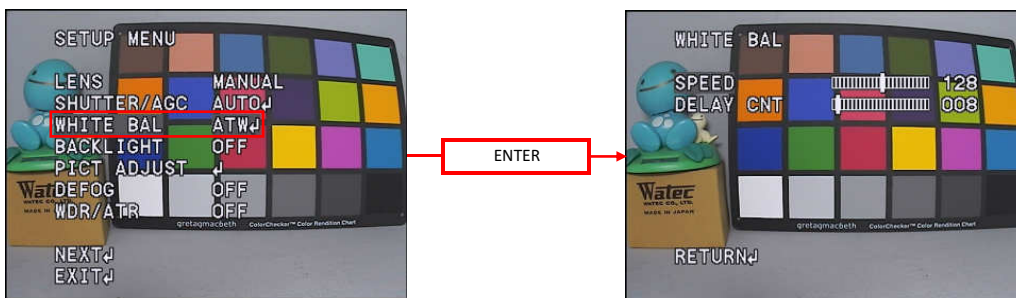

WB	(ATW SETUP Menu)	OPERATION
ATW	SPEED	<p>Set the pull-in speed. The lead-in speed can be set in the range 1-255.</p> <p>The lower the set value, the faster the pull-in speed, and the larger the set value, the slower the pull-in speed.</p> <p>*Note : Color oscillation is likely to occur if the pull-in speed is set too fast.</p> <p>*Default : 128</p>
	DELAY CTL	<p>Set the time from the changes in color temperature to the start of white balance control.</p> <p>Selectable in the range 1-255. The lower the set value, the faster to start WB control, the higher the set value, the slower to start WB control.</p> <p>*Default : 008</p>

3.5.2 Push White Balance(PUSH)

PUSH controls the white balance over a wider color temperature range than ATW and maintains color reproducibility regardless of subject conditions.

*Speed control setting is not available.

3.5.3 Preset White Balance(USRE1 5100K/USER2 6300K)

For the preset white balance, you can select the white balance correction value from the predetermined color temperature of USER 1 (5100 K) or USER 2 (6300 K). When selecting either USER 1 (5100 K) or USER 2 (6300 K), pressing the ENTER will display the SETUP menu for each WB. Move the cursor up or down with the UP / DOWN and use the LEFT / RIGHT to adjust items.

OB-GAIN

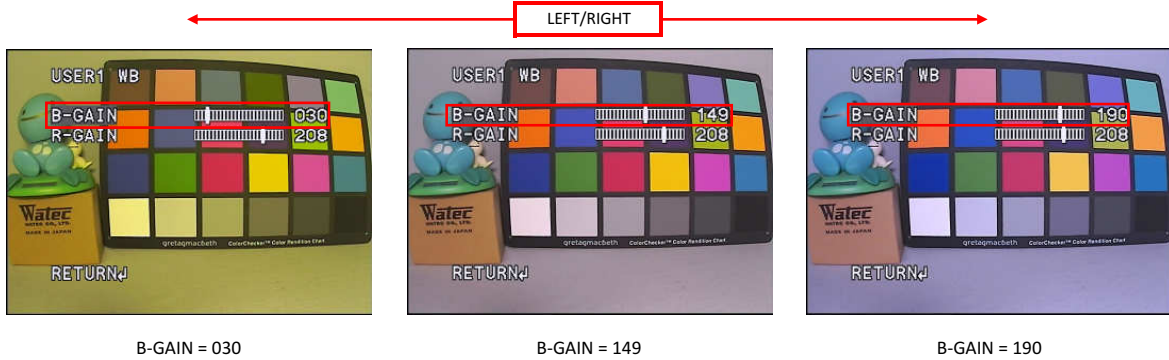

OR-GAIN

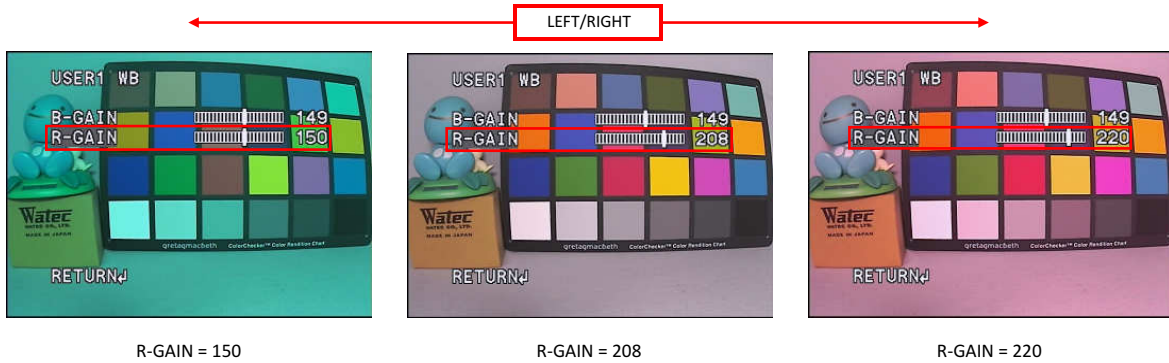

PRESET WB	(SUB MENU)	OPERATION
5100K/6300K	B-GAIN	Set B-GAIN of the white balance correction value. B-GAIN can be set in the range of 000-255. When the set value is decreased, the screen will be corrected to the yellow side, and when it is increased the screen will be corrected to the blue side. *The factory default value may vary.
	R-GAIN	Set the R-GAIN of the white balance correction value. R-GAIN can be set in the range of 000 - 255. When the set value is decreased, the screen will be corrected to the cyan side, and when it is increased the screen will be corrected to the red side. *The factory default value may vary.

3.5.4 Manual White Balance(MANUAL)

MANUAL WB enables to set the white balance correction value arbitrarily.

When MANUAL is selected, press the ENTER to display the manual white balance setting menu. Please use the LEFT / RIGHT to adjust items.

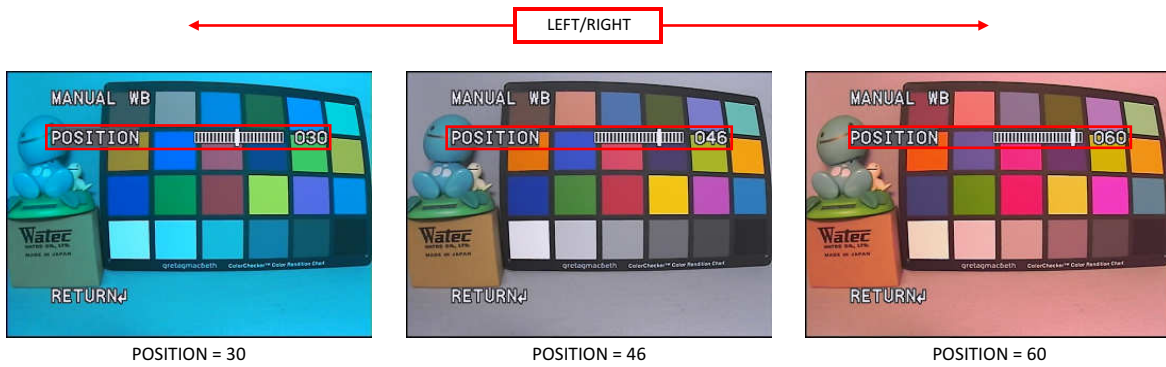

WHITE BAL	(SUB MENU)	OPERATION
MANUAL	POSITION	<p>Set the manual white balance correction value POSITION. POSITION can be set in the range of 000-063.</p> <p>When the set value is decreased, the screen will be corrected to the blue side, and when it is increased the screen will be corrected to the red side.</p> <p><u>*Default : 41</u></p>

3.5.5 Push Lock White Balance(PUSH LOCK)

PUSH LOCK adjusts the white balance under actual illumination and it can be corrected accurately even if the color temperature is unknown.

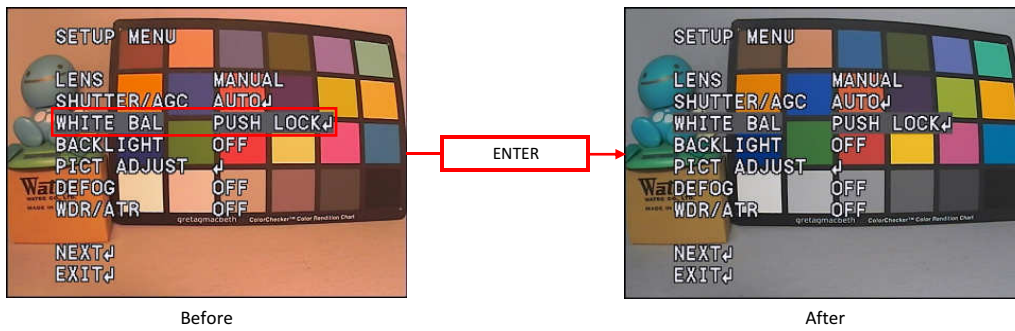

Before

After

OPUSH LOCK adjustment method

Image an achromatic object such as white paper under the actual lighting in the entire screen and press the ENTER.

Confirm the correction and release the ENTER. It will be completed when the paper is corrected to white.



Step (1) Before

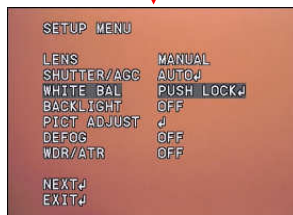

Step (2) Place the white paper in the entire screen



Step (3) Press the ENTER to start the correction

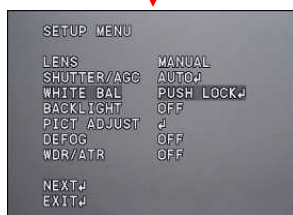

Step (4) Confirm the correction and release the ENTER
(*When it is succeeded, the white paper becomes white in the screen.)



Step (5) After

3.6 Back Light Compensation (BACKLIGHT)

Set the backlight compensation mode (BACKLIGHT). Backlight compensation mode can be selected from Backlight Compensation (BLC) and Highlight Correction (HLC). Move the cursor on BACKLIGHT and use LEFT / RIGHT to select OFF, BLC or HLC.

*Default : OFF



○ Back light compensation(BLC)

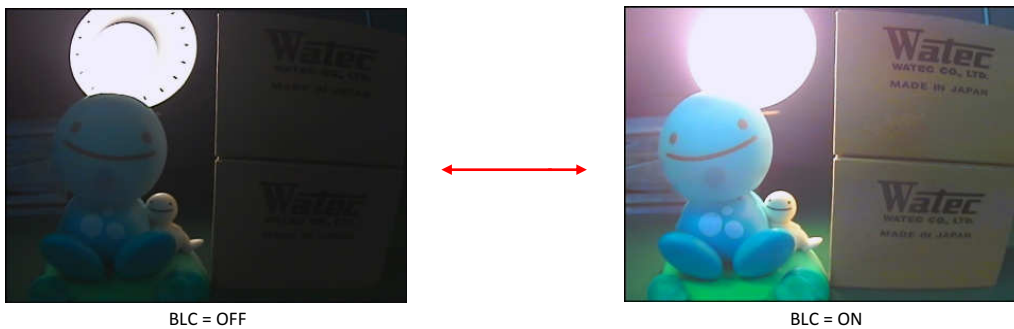

○ Highlight compensation (HLC)

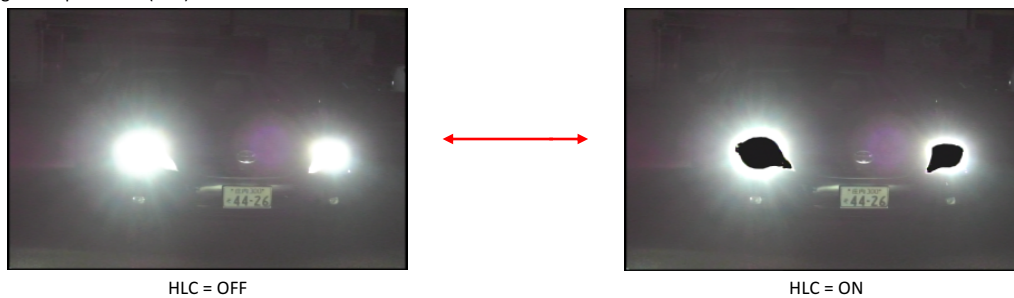

BACKLIGHT	OPERATION
OFF	No operation
BLC	Backlight compensation(BLC) operates. BLC is performed by increasing the brightness of the entire screen such that the subject that is blackened by backlight will have the proper brightness. When there is a dark subject, the BLC operates such that the correct brightness will be obtained. *When the 『3.9.2 Wide Dynamic Range』 function is ON, BLC can not be selectable.
HLC	Highlight compensation(HLC) operates. HLC reduces the burden on the observer's eyes by masking a strong light source in the dark and improves the deteriorated visibility with a strong light source.

3.7 Picture Adjust(PICT ADJUST)

Adjust image quality. Move the cursor to PICT ADJUST and press the ENTER to display the PICT ADJUST menu. Move the cursor up or down with UP / DOWN and select the item you want to adjust.

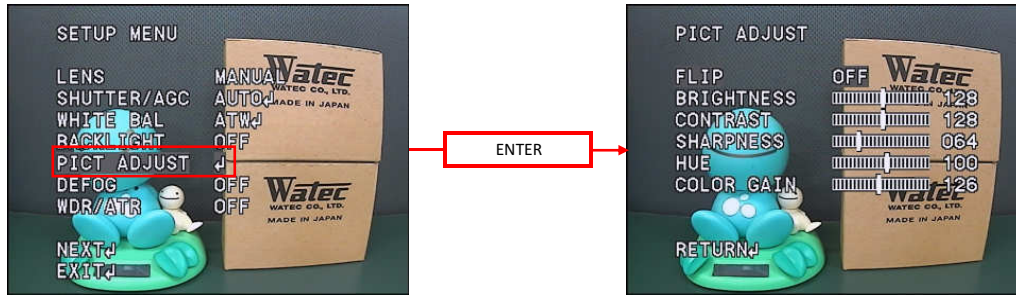

3.7.1 Image Flip(FLIP)

Set the image Flip(FLIP) processing. Use the LEFT/RIGHT to select from normal (OFF), horizontal flip (H - FLIP), vertical flip (V - FLIP) and horizontal - vertical image flip. (HV - FLIP).

*Default : OFF

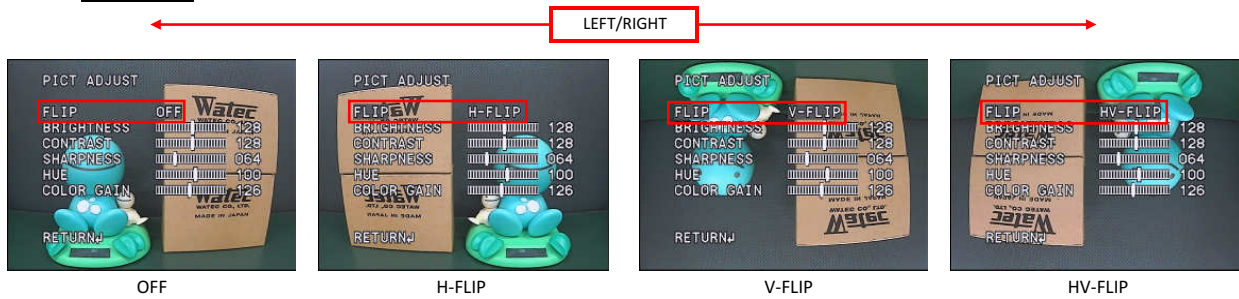

MIRROR	OPERATION
OFF	Normal image
H-FLIP	Horizontal image flip
V-FLIP	Vertical image flip
HV-FLIP	Horizontal and vertical image flip. Rotating the image by 180 degrees.

3.7.2 Brightness(BRIGHTNESS)

Set the brightness(BRIGHTNESS)settings, Use the LEFT/RIGHT to adjust the brightness.

*Default : 128



CONTRAST	OPERATION
000-255	The smaller the setting value, the darker the image, and the larger the setting value the brighter the image.

3.7.3 Contrast(CONTRAST)

Set the contrast (CONTRAST) settings. Use the LEFT/RIGHT to adjust the contrast.

*Default : 128

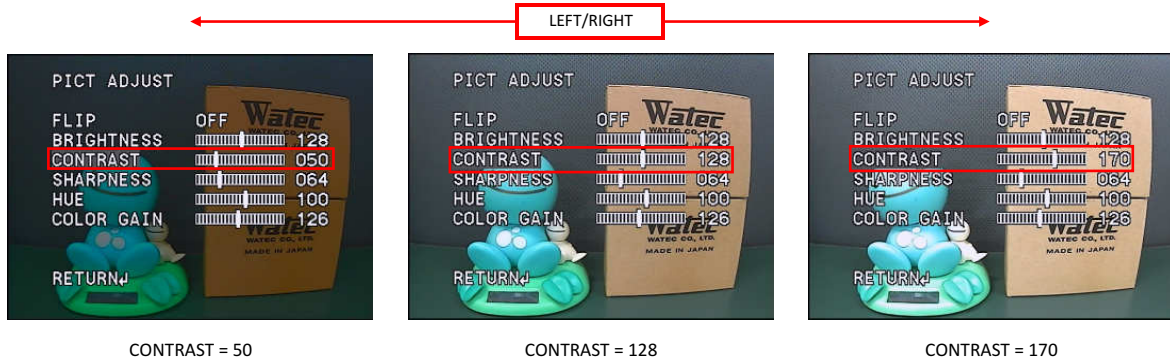

CONTRAST	OPERATION
000-255	The smaller the setting value, the lower the contrast. The larger the setting value, the higher the contrast.

3.7.4 Edge Enhancement(SHARPNESS)

Sets the intensity of edge enhancement (SHARPNESS). It enhances the visual effects of resolution by emphasizing the outline portion of the image. Use the LEFT / RIGHT to set SHARPNESS.

*Default : 64

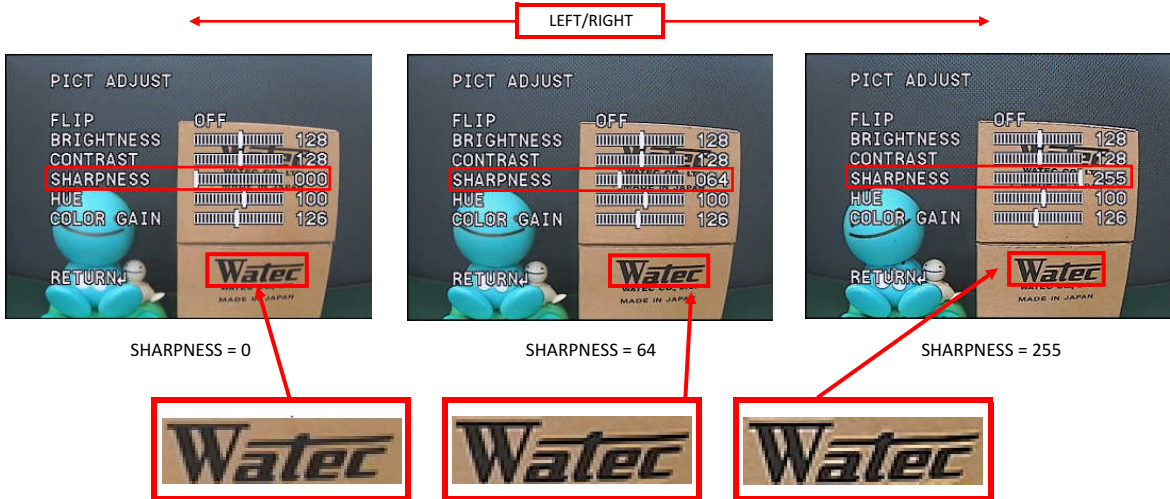

SHARPNESS	OPERATION
000-255	The larger the setting value, the higher the edge enhancement level of the entire screen, the sharper the image, but the noise become marked.

3.7.5 Chroma Settings(HUE,COLOR GAIN)

Set the chroma level (HUE, COLOR GAIN). You can set your arbitrary color by adjusting color gain (COLOR GAIN) and color hue (HUE).

Use the LEFT / RIGHT to adjust the chroma.

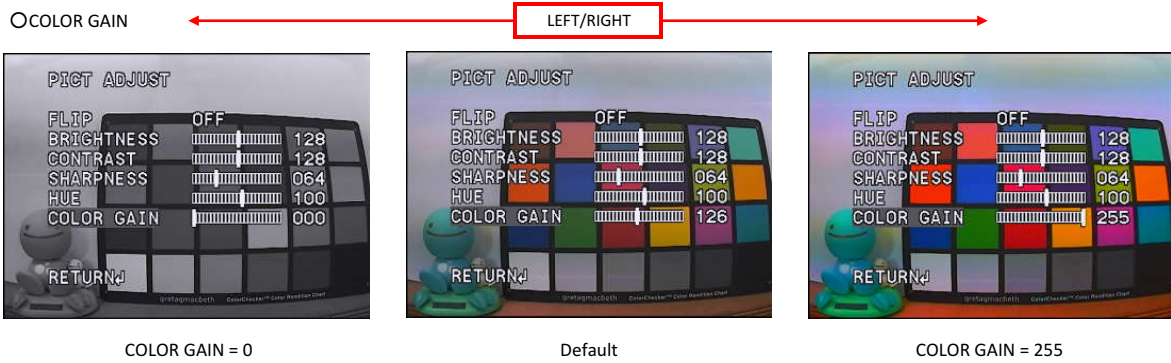

(ADJUST Menu)	OPERATION
HUE	HUE can be set in the range of 000-180. Adjust the hue. <u>*The factory default value may vary.</u>
COLOR GAIN	COLOR GAIN can be set in the range of 000 - 255. Adjust the color gain. <u>*The factory default value may vary.</u>

* The above explanation is a guide only, make adequate evaluation in the use environment.

3.8 Defog(DEFOG)

Set the defog (DEFOG) settings. When fog or smoke occurs, the contrast of the screen decreases and the visibility deteriorates.

The defog function can improve the contrast of visually impaired images with fog and or smoke and improve visibility.

Selectable from OFF or AUTO. Pressing the ENTER when AUTO is selected displays the DEFOG Menu.

Use the LEFT / RIGHT to select the DEFOG setting.

*Default : OFF

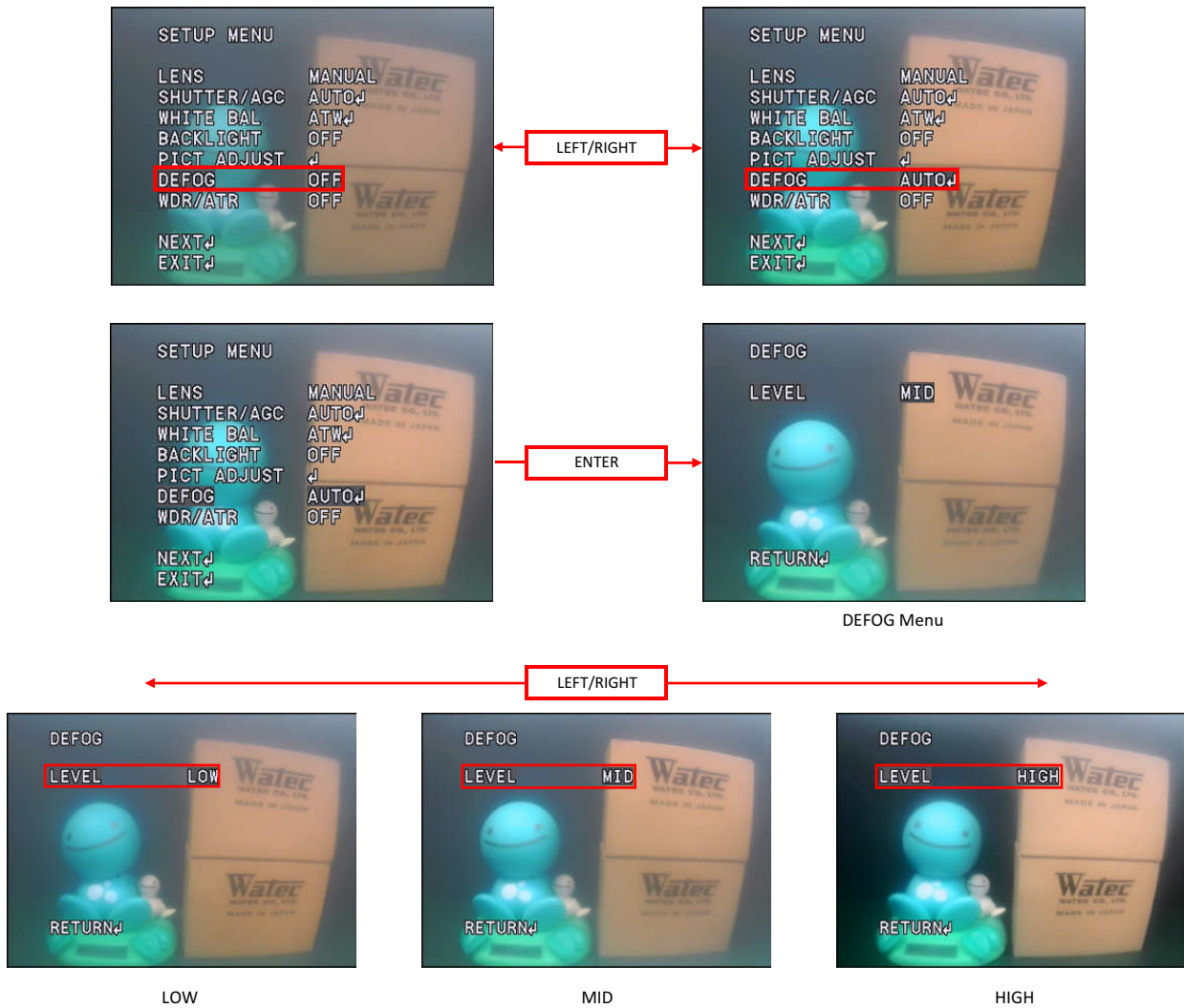

DEFOG	SUB MENU	OPERATION
OFF	-	No operation
AUTO	LOW	DEFOG automatically operates when foggy condition is detected. LOW : Fog detection sensitivity low, contrast correction low
	MID	MID : Fog detection sensitivity mid, contrast correction mid
	HIGH	HIGH : Fog detection sensitivity high, contrast correction high The larger that set value, the higher the contrast. It improves the visibility. *Default : MID

3.9 Wide Dynamic Range / Tone Correction (WDR / ATR)

Set the wide dynamic range / tone correction function. When you take a subject with a large contrast difference such as a backlight condition, some of the subjects will be overexposure or underexposure. The wide dynamic range / tone correction (WDR / ATR) suppresses overexposure or underexposure of the subject under the conditions and corrects it to a natural image. Use the LEFT / RIGHT to select from OFF, ATR or WDR.

*Default : OFF

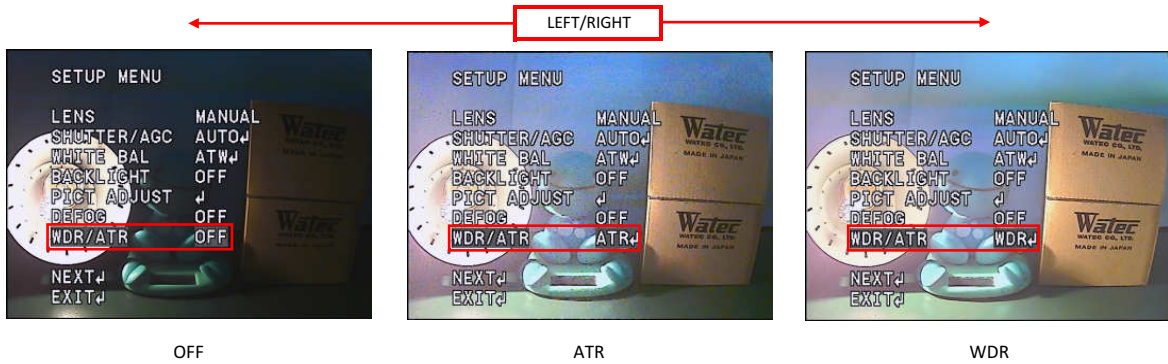

3.9.1 Adaptive Tone-Curve Reproduction (ATR)

Press the ENTER when ATR is selected to display the ATR menu.

You can select the correction amount of brightness and contrast of tone correction from LOW, MID, HIGH.

*Default : MID

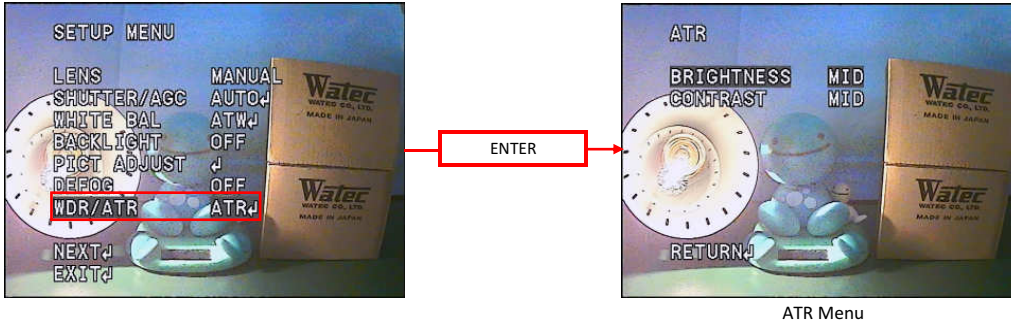

BRIGHTNESS ← LEFT/RIGHT →



CONTRAST ← LEFT/RIGHT →



WDR/ATR	SUB MENU	OPERATION
ATR	BRIGHTNESS	Set the brightness correction amount of the tone correction function. The larger the setting value, the brighter the image, the smaller the setting value, the darker the image.
	CONTRAST	Set the contrast correction amount of the tone correction. Increasing the setting value improves the visibility and can capture the bright and dark areas at the same time. Decreasing the set value will result in a natural image with overall contrast.

3.9.2 Wide Dynamic Range (WDR)

Press the ENTER when WDR is selected to display the WDR menu.

You can select the correction amount of wide dynamic range brightness and contrast from LOW, MID, HIGH.

*Default : MID

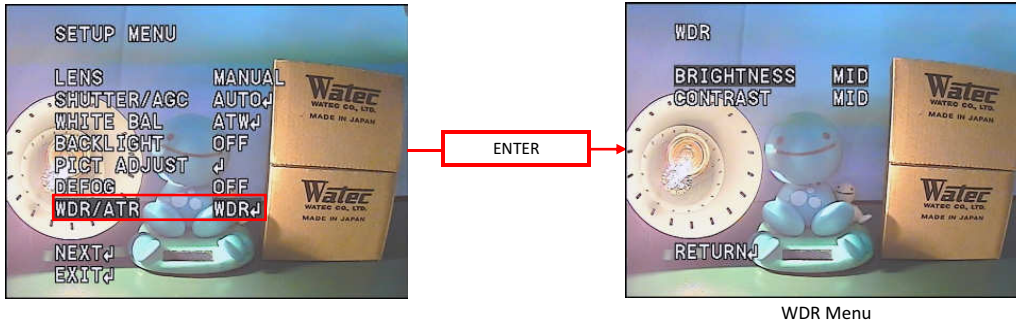

← BRIGHTNESS ← LEFT/RIGHT →



← CONTRAST ← LEFT/RIGHT →



WDR/ATR	SUB MENU	OPERATION
WDR	BRIGHTNESS	Set the brightness correction amount of the wide dynamic range function. The larger the setting value, the brighter the image, the smaller the setting value, the darker the image.
	CONTRAST	Set the contrast correction amount of the wide dynamic range. Increasing the setting value improves the visibility and can capture the bright and dark areas at the same time. Decreasing the set value will result in a natural image with overall contrast.

3.10 Day & Night Function (DAY/NIGHT)

The model has a new system of mechaless day and night function that does not use the ICR (Infrared Cut filter Removal) mechanism.

The color mode and monochrome mode automatically switch according to the ambient brightness change.

*OSD setting items are not available.

3.11 IR LED Control(IR LED)

Set the IR LED control (IR LED) function. It is a function that modulates the infrared emitter by combining the PWM signal from the IR LED control connector and the infrared emitter equips the digital input. Use the LEFT/RIGHT to select AUTO, FIX, OFF.

When AUTO or FIX is selected, press the ENTER to display the setting menu.

*Default : AUTO

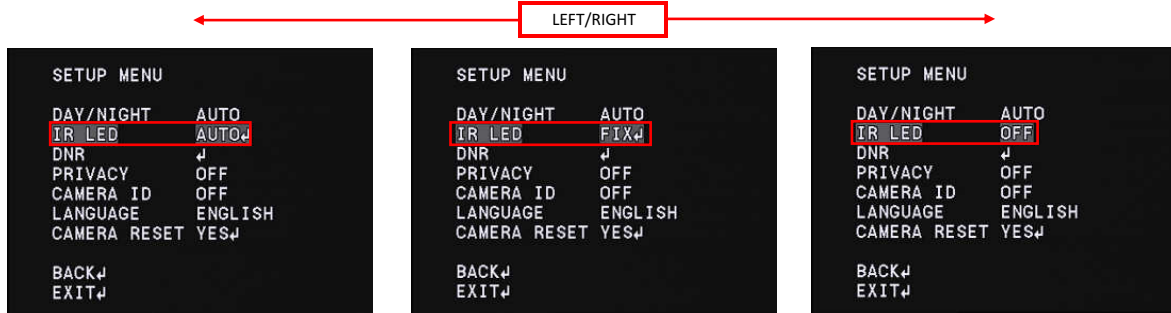

IR LED	(SUB MENU)	OPERATION
AUTO	LEVEL MAX	Set the limit level of the IR LED control PWM signal. Limit level of IR LED control PWM signal can be set within the range of 006 - 255. The higher the LEVEL, the greater the duty ratio of the PWM signal. When LEVEL 255 is selected, the DUTY ratio will be 100%. In AUTO mode, PWM signal outputs only when DAY / NIGHT switches to NIGHT mode. The DUTY ratio of the PWM signal changes according to the illuminance. The DUTY ratio increases when the illuminance is high and decreases when it is low.
FIX	LEVEL	Set the level of the IR LED control PWM signal. The level of the IR LED control PWM signal can be set within the range 0-255. When LEVEL 0 is selected, the DUTY ratio of the PWM signal will be 0%. The higher the LEVEL, the greater the DUTY ratio of the PWM signal and when LEVEL 255 is selected the DUTY ratio will be 100%. In FIX mode, DUTY ratio always outputs fixed PWM signal regardless of DAY / NIGHT judgement.
OFF	-	The IR LED control function is turned OFF. The PWM signal does not output from the IR LED control connector.

3.12 Noise Reduction(DNR)

Set the noise reduction (DNR) function. Noise reduction is a function to reduce image noise to improve the image quality of the camera. Especially, it reduces the noise that occurs when the gain becomes high in low illumination environment.

Move the cursor to DNR and press the ENTER to display the DNR menu. Move the cursor up or down with UP / DOWN to adjust items.

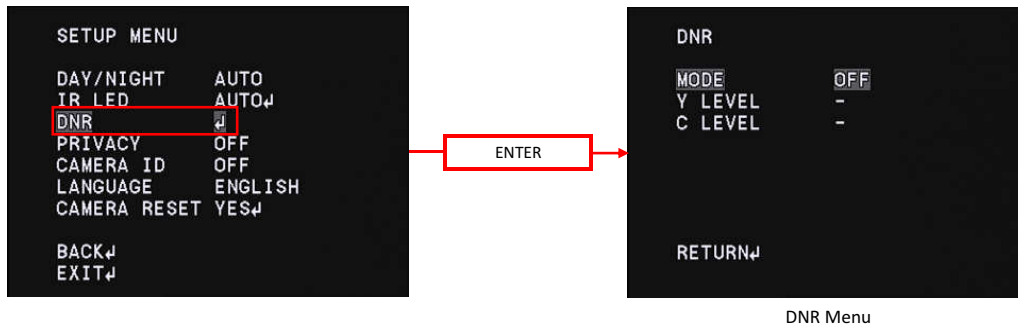

ODNR MODE setting

Set the operation mode of noise reduction.

*Default : OFF

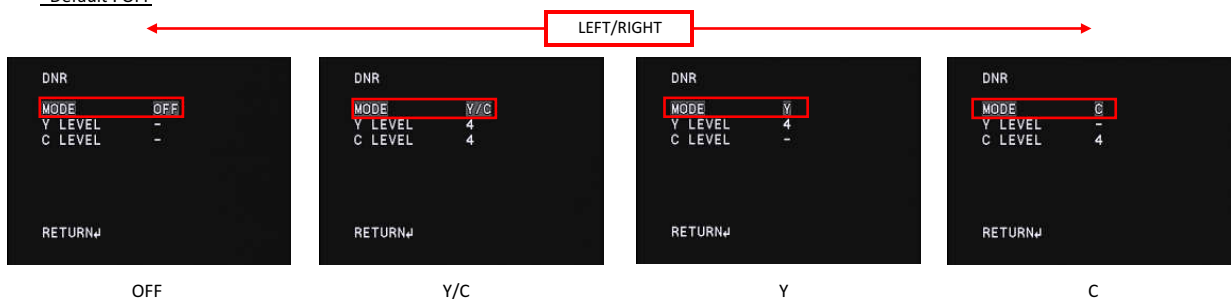

O LEVEL setting

Set the correction level of noise reduction.

Use the LEFT / RIGHT to move the cursor and adjust the noise reduction correction level

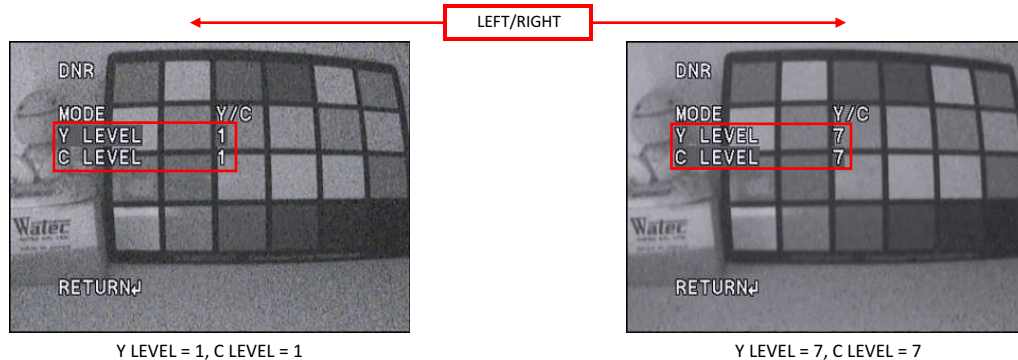

DNR MENU	(SUB MENU)	OPERATION
MODE	OFF	No operation
	Y	Noise reduction operates on Y component independently.
	C	Noise reduction operates on C component independently.
	Y/C	Noise reduction operates on Y component and C component while using the 2 filters.
Y LEVEL	001 - 007	Set Y component correction level of noise reduction. The greater the set value, the stronger the effect of noise reduction. <u>*Default : 004</u>
C LEVEL	001 - 007	Set C component correction level of noise reduction. The greater the set value, the stronger the effect of noise reduction. <u>*Default : 004</u>

3.13 Privacy Mask(PRIVACY)

Set the privacy mask (PRIVACY). The privacy mask can hide areas that you do not want to display on the screen. Up to 16 masks can be displayed on the screen. You can set the display area, color, darkness and mosaic processing for each mask independently.

Move the cursor to PRIVACY and select ON or OFF with LEFT / RIGHT. Press the ENTER when ON is selected displays the PRIVACY menu.

Move the cursor up and down with UP/DOWN and adjustment the item you want to adjust while using the LEFT / RIGHT.

*Default : OFF

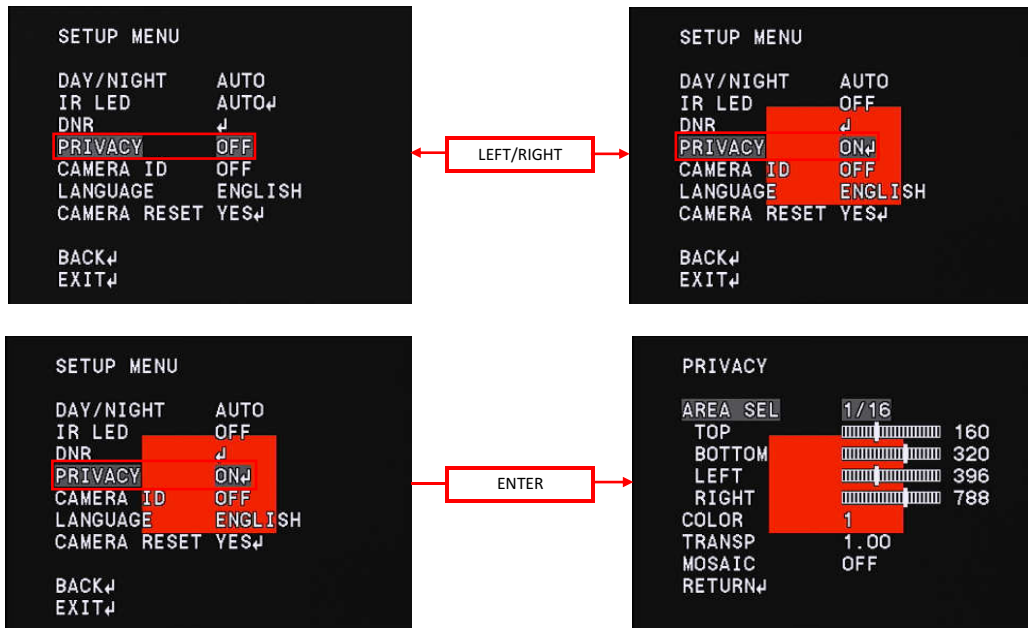

(PRIVACY Menu)	OPERATION
AREA SEL	Select the mask number to be set. The masking number is selected from 1/16 to 16/16. *Default : 1/16
TOP	Set the top side of the masked area. It can be set within the range of 000 - 480 (576) *(576) : Set value in PAL
BOTTOM	Set the bottom side of the masked area. It can be set within the range of 000 - 480 (576). It can not be set to a smaller value than TOP. *(576) : Set value in PAL
LEFT	Set the left side of the masked area. It can be set within the range of 000 - 1184 (1174). *(1174) : Set value in PAL
RIGHT	Set the right side of the masked area. It can be set within the range of 000 - 1184 (1174). It can not be set to a smaller value than LEFT *(1174) : Set value in PAL
COLOR	Set the masking color. You can select the color from the following 8 colors. 1 (RED), 2 (GREEN), 3 (BLUE), 4 (YELLOW), 5 (CYAN), 6 (MAGENTA), 7 (WHITE), 8 (BLACK) *Default : 1 (RED)
TRANSP	Set the transparency of the masking. The masking transparency can be selected from 0.00, 0.50, 0.75 and 1.00. The higher the set value, the lower the transparency of the masking, 1.00 will completely mask the masking area. *Default : 1.00
MOSAIC	Set ON/OFF of mosaic processing. Mosaic processing on the masking area available when ON is selected. *When TRANSP is set to 1.00, mosaic processing not available. *Default : OFF

○ AREA SEL settings

Select the masking area number to be set.

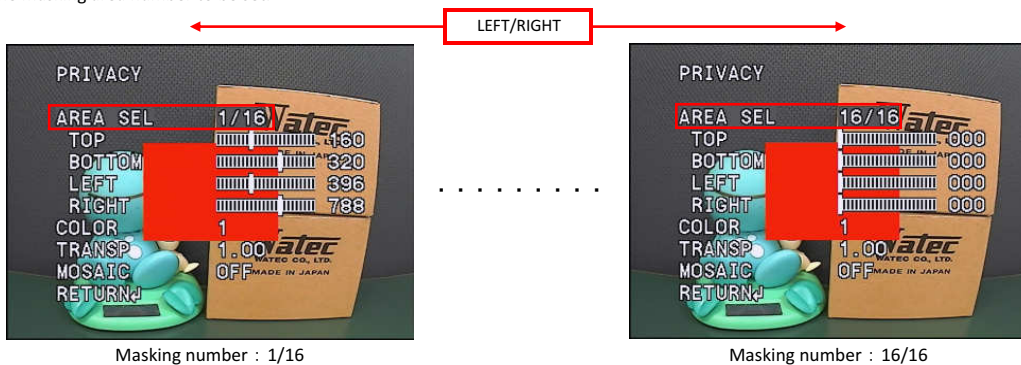

○ Masking area settings

Use the UP/DOWN/LEFT/RIGHT to select the masking area.



(1) Move the cursor to TOP with UP/DOWN and use LEFT/RIGHT to adjust the position of the top side of the masking area.

*When you set the TOP value close to 000, the masking area will move to the top of the screen and set the value close to the limit, it will move to the bottom of the screen.



(2) Move the cursor to BOTTOM with UP/DOWN and use LEFT/RIGHT to adjust the position of the bottom side of the masking area.

*When you set the BOTTOM value close to 000, the masking area will move to the top of the screen and set the value close to the limit, it will move to the bottom of the screen.

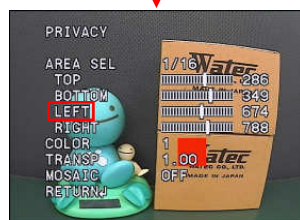

(3) Move the cursor to LEFT with UP/DOWN and use LEFT/RIGHT to adjust the position of the left side of the masking area.

*When you set the LEFT value close to 000, the masking area will move to the left side of the screen and set value to the limit, it will move to the right side of the screen.

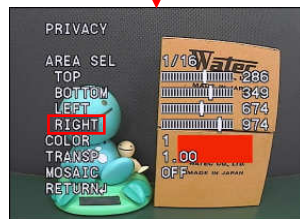

(4) Move the cursor to RIGHT with UP/DOWN and use LEFT/RIGHT to adjust the position of the right side of the masking area.

*When you set the RIGHT value close to 000, the masking area will move to the left side of the screen and set value to the limit, it will move to the right side of the screen.

*Default setting of the masking area is masking number 1 in the center of the screen. For the masking number 2 to 16, TOP, BOTTOM, LEFT and RIGHT are set to 000 in the default setting and NO masking area is specified. Set the masking area according to above procedures.

*NOTE : When the same value is set for TOP and BOTTOM or LEFT and RIGHT, the masking area is not displayed.

OMasking COLOR setting

Set the masking color.

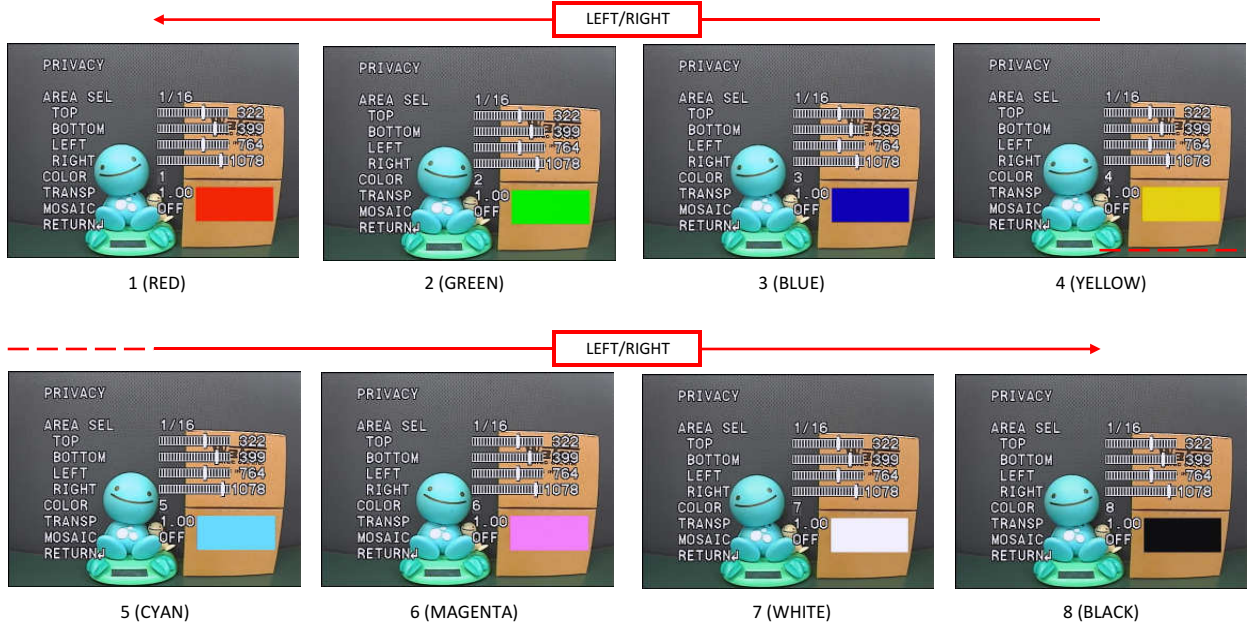

OTRANSparency setting.

Set the transparency setting.

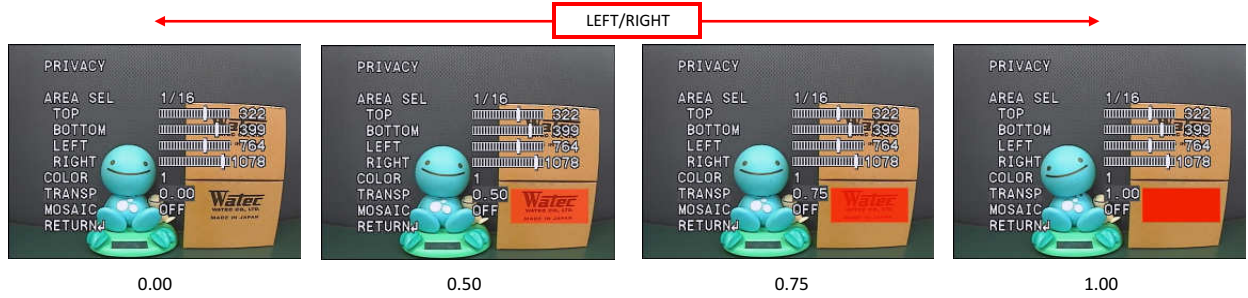

OMOSAIC setting

Set the mosaic processing ON / OFF

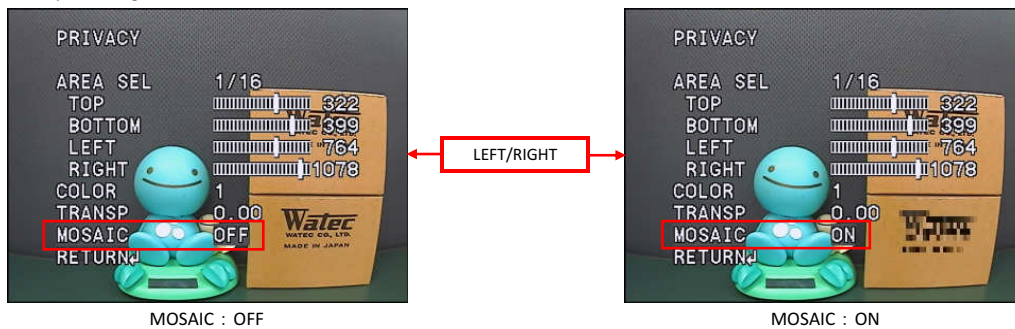

3.14 Camera ID(CAMERA ID)

Set the camera ID (CAMERA ID). This function displays arbitrary characters on the screen. It is effective for identifying the camera on the screen when using multiple cameras. Move the cursor to CAMERA ID with UP/DOWN and use the LEFT/RIGHT to select ON / OFF.

*Default : OFF

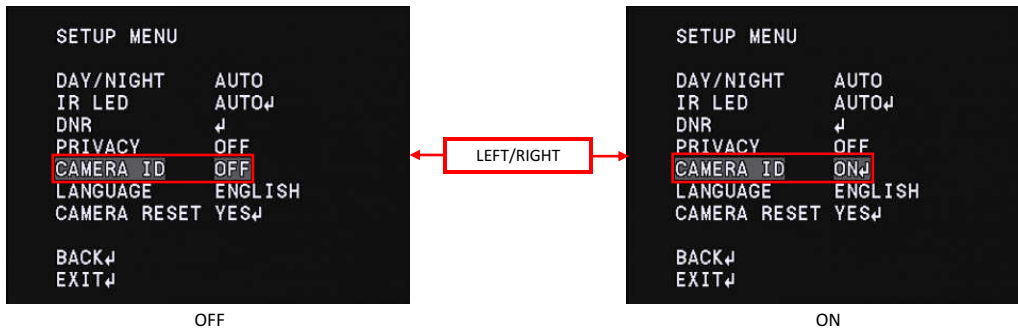

When ON is selected, press ENTER to display CAMERA ID menu. Use the UP/DOWN/LEFT/RIGHT to select the character to be displayed and use the ENTER to enter the characters.

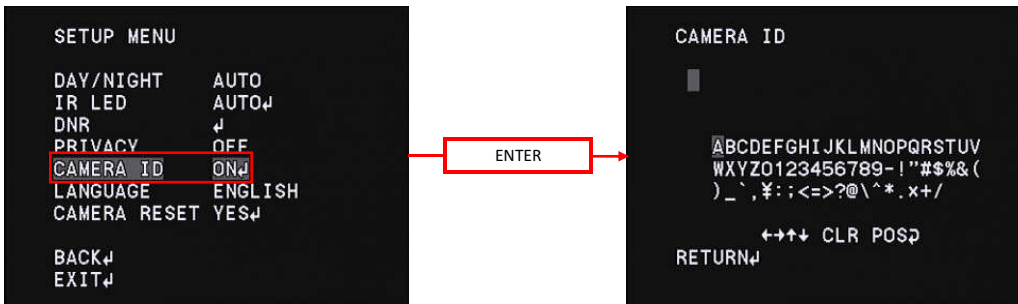

CAMERA ID	(CAMERA ID SETUP Menu)	OPERATION
OFF	—	CAMERA ID is hidden.
ON	(input)	The characters that can be entered are displayed in the CAMERA ID SETUP menu. Up to 52 characters such as alphabet (capital), numbers, and symbols can be entered. *Default : blank
	←→ ↑ ↓	Set the position of the cursor when entering characters. After entering a character, you can change the character by moving the cursor to the character you want to change and entering another character.
	CLR	Delete the entered characters.
	POS	Set the display position of the input character. Move the cursor to POS and press the ENTER to display a window for setting the display position of the character. *Default position : Upper left of the screen.

○ Character entering setting

Use the UP/DOWN/LEFT/RIGHT/ENTER to set the CAMERA ID.

(4) Move the cursor to CAMERA ID and press the ENTER so that the CAMERA ID menu will be displayed again.

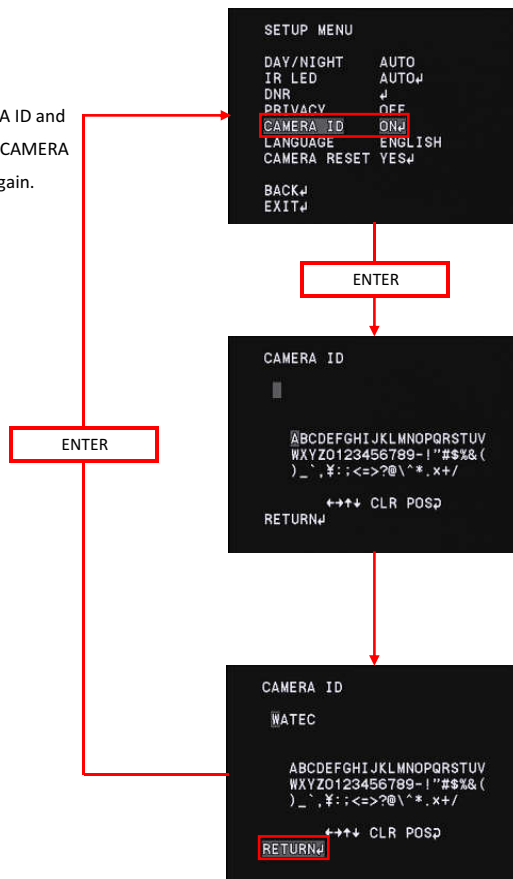

(1) Move the cursor to CAMERA ID and press the ENTER.

(2) Use the UP/DOWN/LEFT/RIGHT to select the character you want to display and use the ENTER to enter the characters.

(3) After entering characters, move the cursor to "RETURN" and press the ENTER to return to SETUP MENU.

○ Display position setting

Move the cursor to POS and press the ENTER to display the display position setting menu.

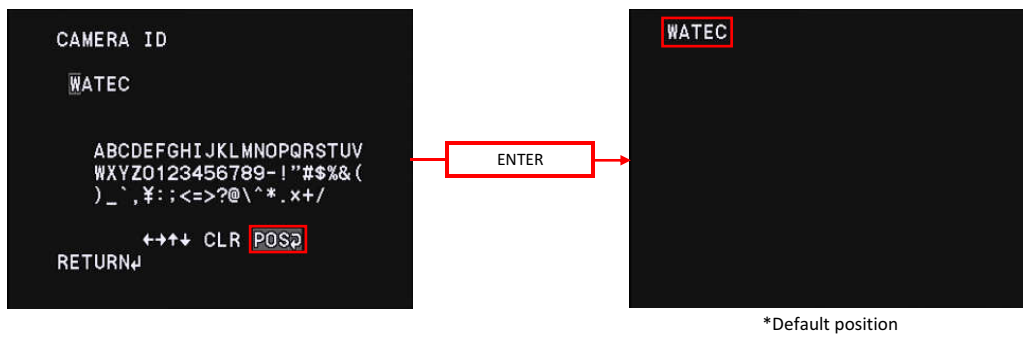

Use the UP/DOWN/LEFT/RIGHT to set the display position. After setting, press the ENTER to return to the CAMERA ID menu.

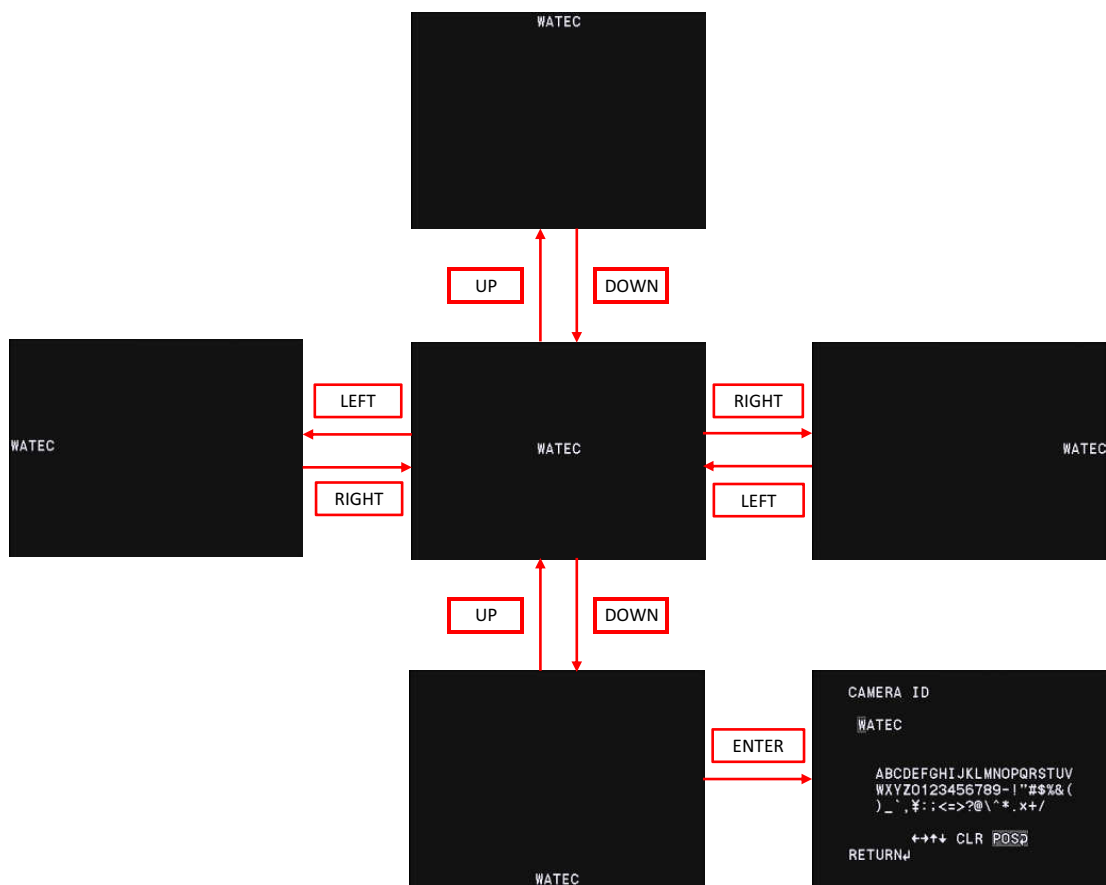

*CAMERA ID will be displayed when the OSD menu screen is turned off. While the OSD menu is displayed, CAMERA ID does not show up.
To turn off the OSD menu, move the cursor to EXIT with UP/ DOWN and press the ENTER to display the EXIT menu.
Move the cursor to SAVE ALL or NOT SAVE with the UP / DOWN, hide the OSD menu by pressing the ENTER.

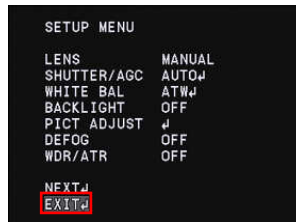

(1) Select EXIT and press the ENTER.

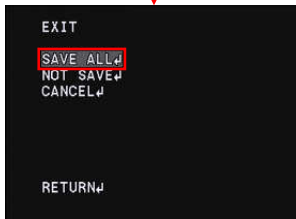

(2) Select SAVE ALL or NOT SAVE and press the ENTER.

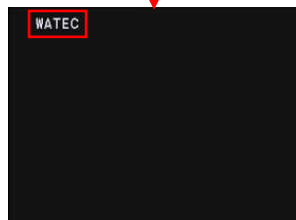

(3) The OSD menu is turned off and the camera ID is displayed.

3.15 Language(LANGUAGE)

Set the language of the OSD menu. You can choose from English, German, French, Russian, Portuguese, and Spanish.

Move the cursor to LANGUAGE with UP/DOWN and use the LEFT / RIGHT to select from ENGLISH, DEUTSCH, FRANCAIS, русский, PORTUGUÊS and ESPAÑOL.

*Default : ENGLISH

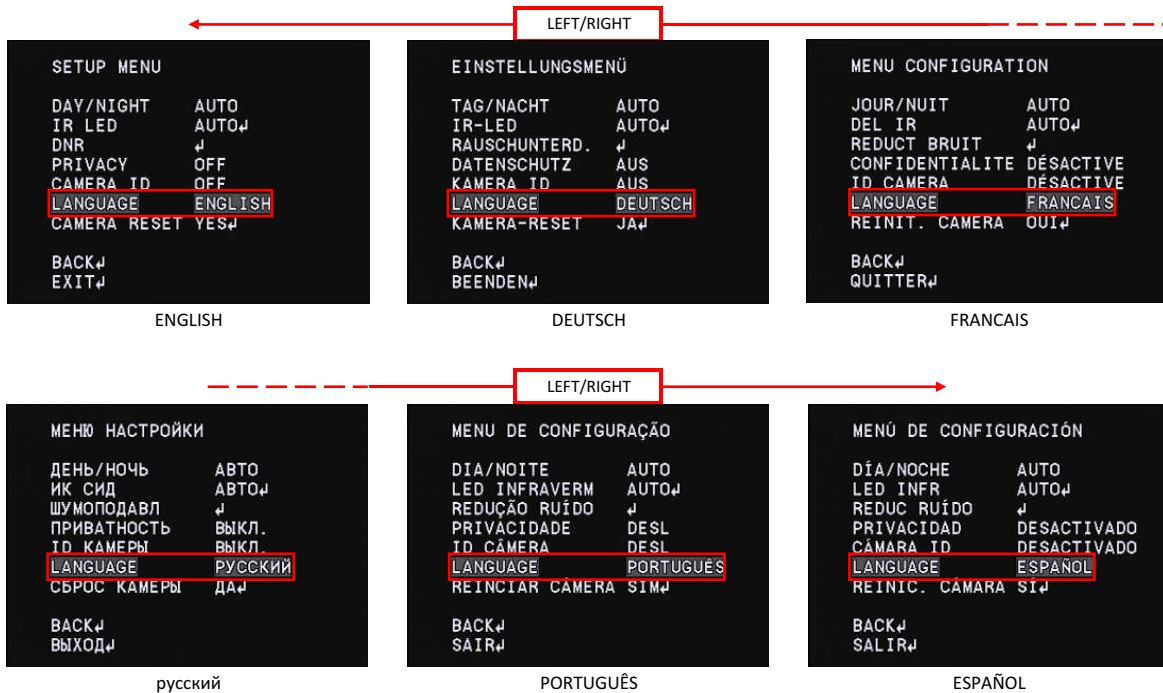

3.16 Factory Reset(CAMERA RESET)

This function returns the camera setting to factory default (CAMERA RESET) function. Even after changing camera settings, you can return the camera to the factory default by executing camera reset. Move the cursor to CAMERA RESET with UP/DOWN and press the ENTER to execute the camera reset.

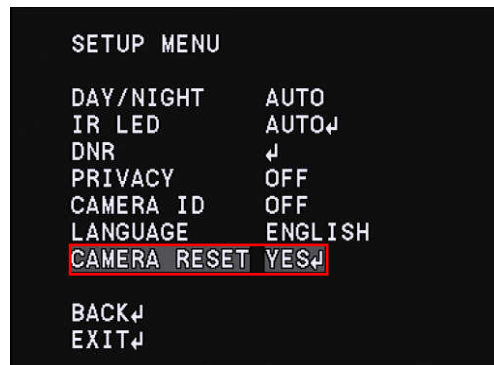

*When you want to save the default setting value after executing the camera reset, save the setting value according to 『3.2 Save setting (SAVE ALL)』

NOTE : When you do not save the setting value prior to turning off the power, the settings will return to the setting value before executing the camera reset.

3.17 EXIT Menu (EXIT)

Exit the OSD menu. Move the cursor to EXIT with UP / DOWN and press the ENTER so that the EXIT menu will be displayed.

In EXIT MENU, you can select SAVE ALL, NOT SAVE, CANCEL, RETURN. Move the cursor with the UP / DOWN and press the ENTER to execute.

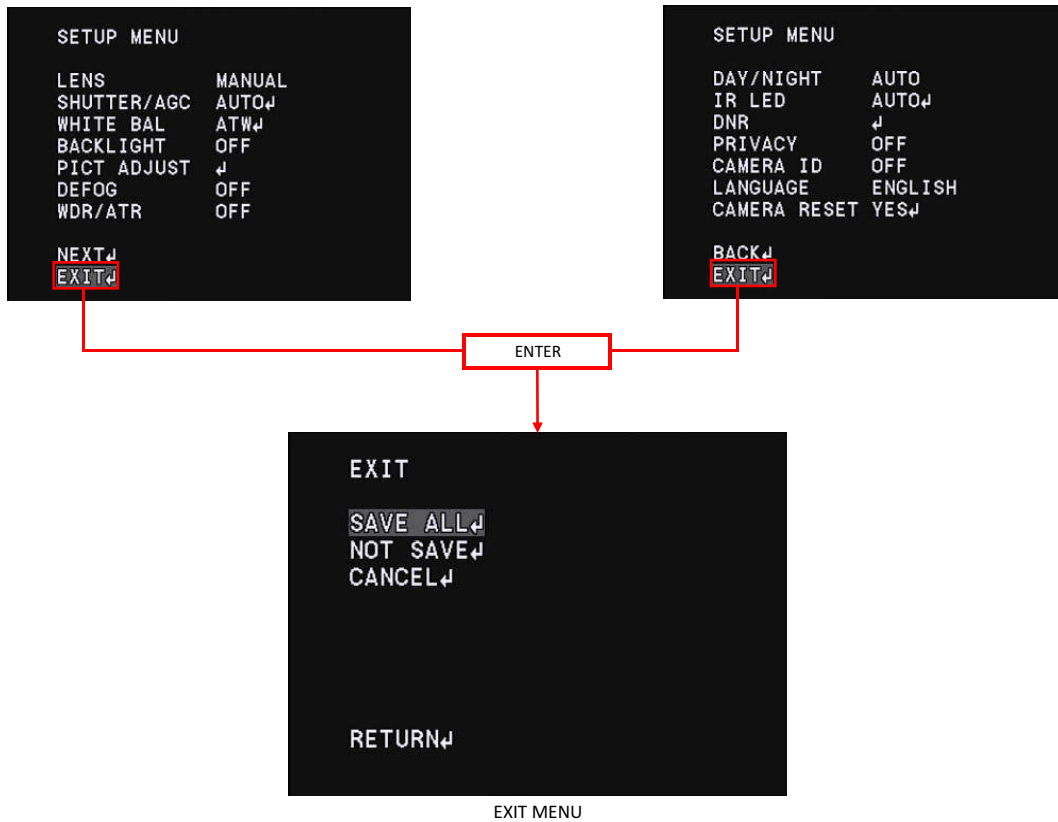

EXIT	OPERATION
SAVE ALL	Save the OSD setting in ROM and close the OSD menu. After turning on the power again, the camera starts with the saved settings.
NOT SAVE	Close the OSD menu without saving the OSD setting in ROM. After turning on the power again, the camera starts with the setting before the new modification was made.
CANCEL	Set the camera setting back to the state before displaying the OSD menu and close the OSD menu.
RETURN	Return to SETUP MENU

4.OSD Menu Tree

- Legend:
- Represents OSD menu item
 - Represents the operation by UP, DOWN and ENTER key of the remote control
 - Represents the operation by RIGHT, LEFT and ENTER key of the remote control
 - Represents a selectable mode and setting value of each menu item
 - Represents the title on the OSD and not a setting item

※LANGUAGE:ENGLISH

Q SETUP MENU

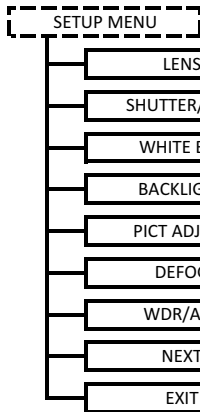

- > to LENS MENU(for auto iris lens advanced settings)
- > to SHUTTER/AGC MENU(for Shutter speed & AGC advanced settings)
- > to WB MENU(for White balance fuction advanced settings)
- > to BACKLIGHT(for setting of HLC function)
- > PICT ADJUST MENU(for picture image advanced settings)
- > DEFOG MENU(for defog control advanced settings)
- > WDR/ATR MENU(for Wide Dynamic Range & Adaptive Tone Reproduction advanced settings)
- > NEXT: to display the next page
- > EXIT MENU

Q SETUP MENU

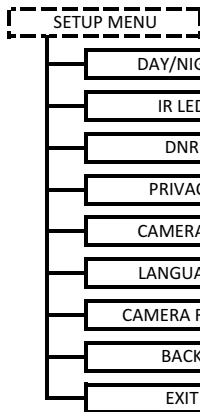

- > DAY/NIGHT MENU(for DAY/NIGHT fuction advanced settings)
- > to IR LED MENU(for IR LED fuction advanced settings)
- > to DNR MENU(for noise reduction function advanced settings)
- > to PRIVACY MENU(for privacy masking function advanced settings)
- > to the CAMERA ID MENU (for Camera ID advanced settings)
- > to Language Menu (for Language switching)
- > to reset all settings to the factory default settings
- > BACK (display the previous page)
- > EXIT MENU

Q EXIT MENU

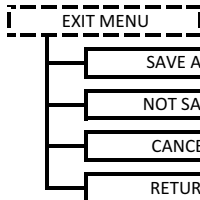

- > Exit OSD Menu and save all the configuration item
- > Exit OSD Menu without saving the configuraition item
- > Exit OSD Menu without reflecting the configuration item
- > BACK to SETUP MENU

Default : in Red

LENS(SETUP MENU)

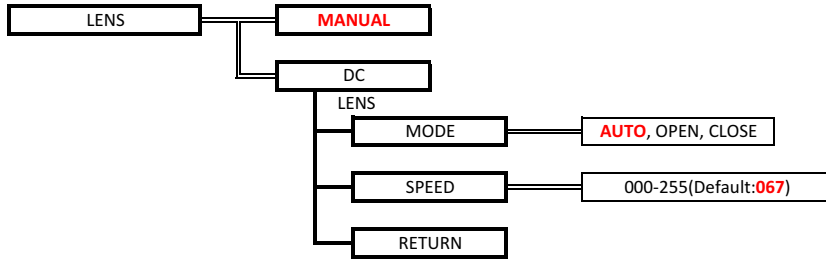

SHUTTER/AGC(SETUP MENU)

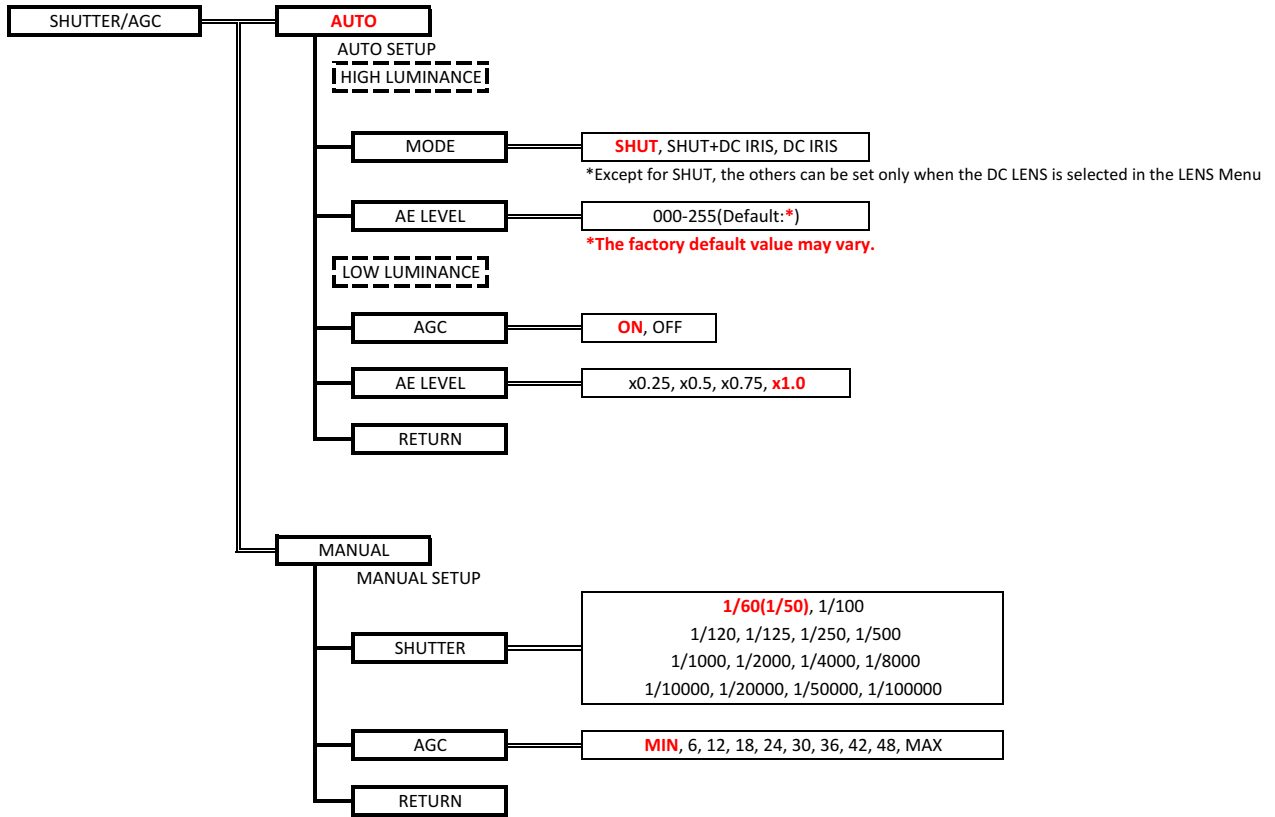

○WHITE BAL(SETUP MENU)

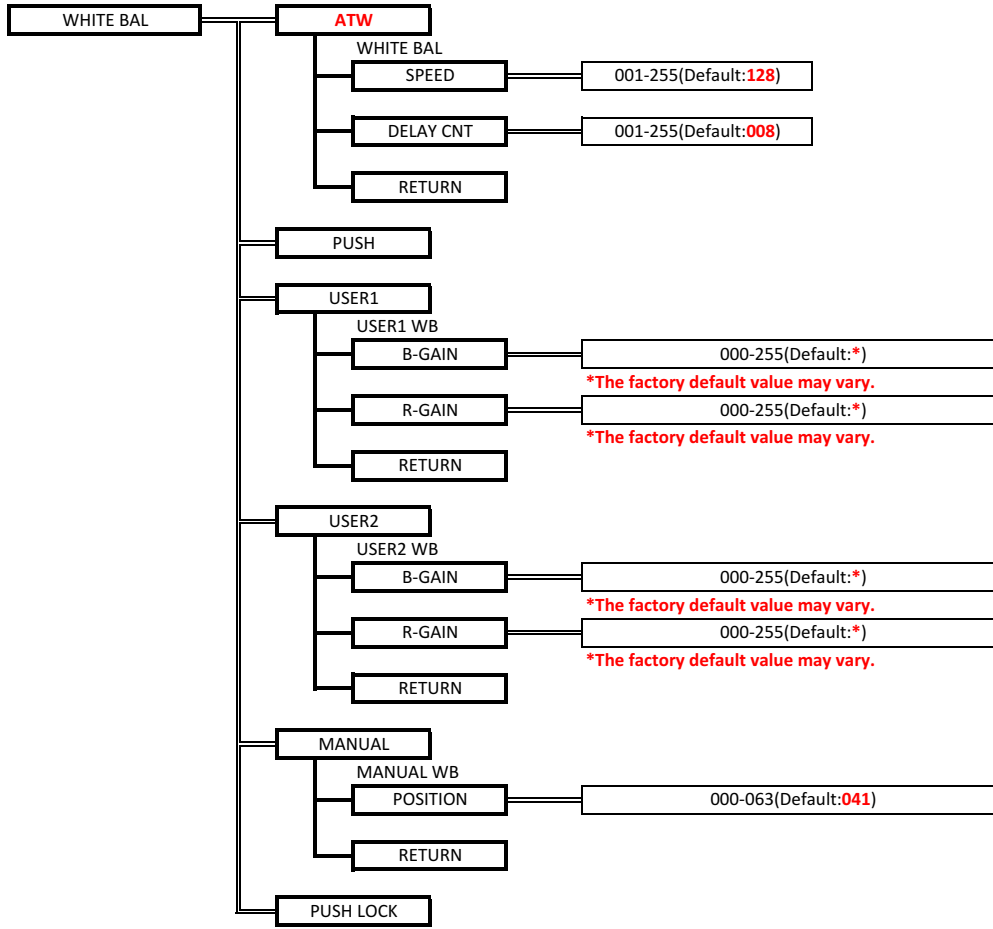

○BACKLIGHT(SETUP MENU)

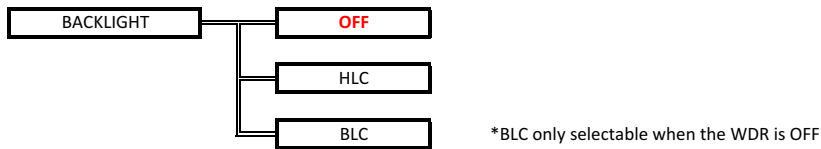

PICT ADJUST(SETUP MENU)

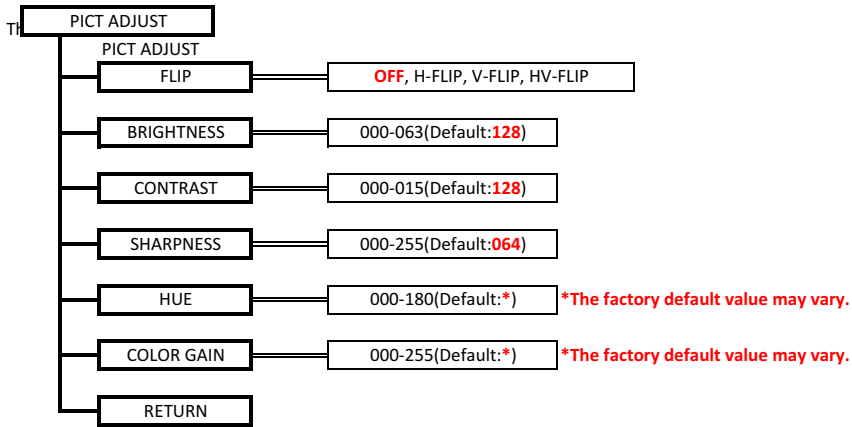

DEFOG(SETUP MENU)

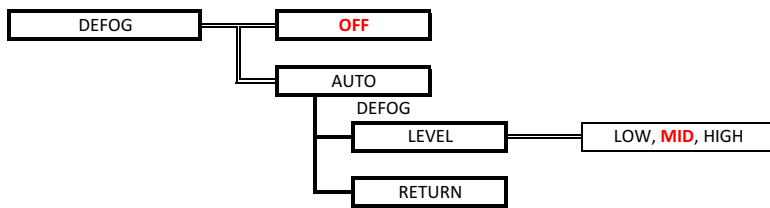

WDR/BLC(SETUP MENU)

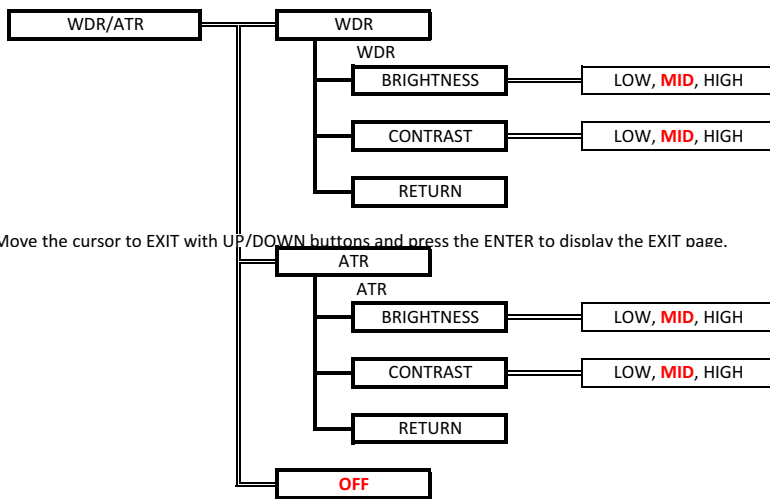

Move the cursor to EXIT with UP/DOWN buttons and press the ENTER to display the EXIT page.

○DAY/NIGHT(SETUP MENU)



○IR LED(SETUP MENU)

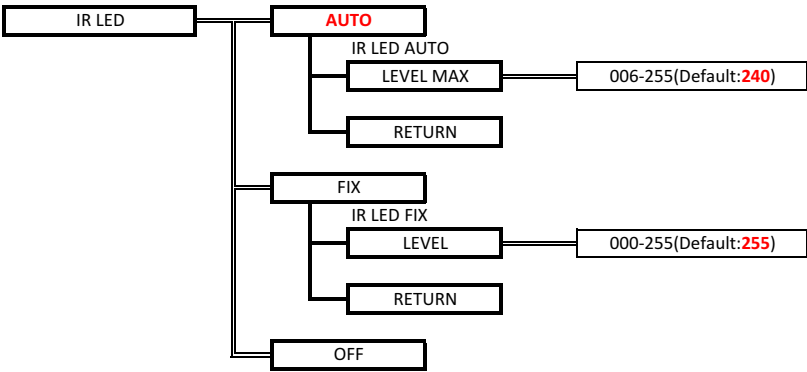

○DNR(SETUP MENU)

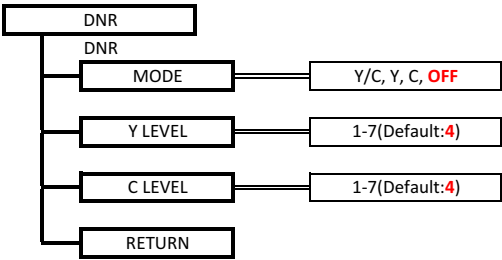

○PRIVACY(SETUP MENU)

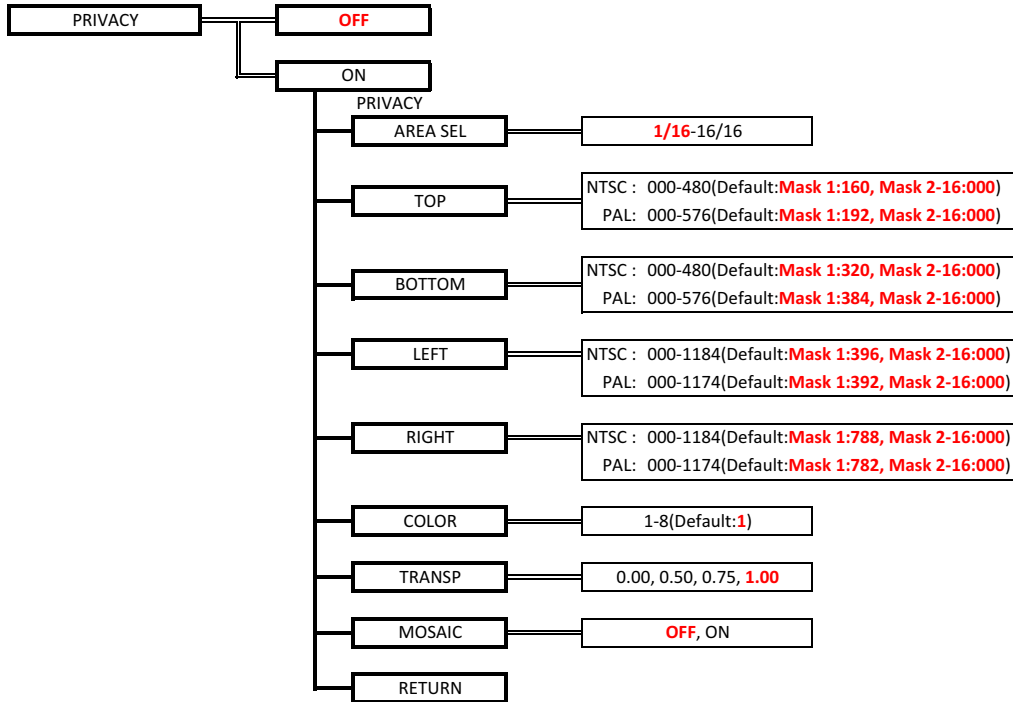

○CAMERA ID(SETUP MENU)

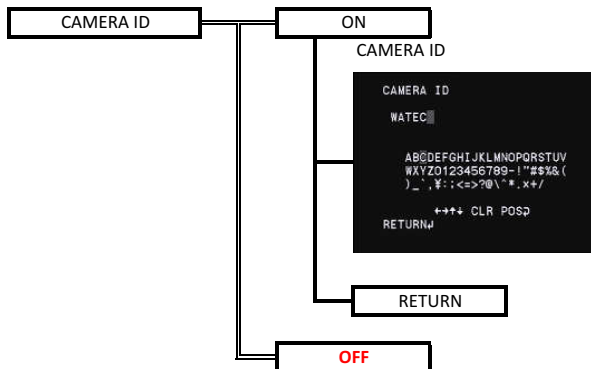

○LANGUAGE(SETUP MENU)

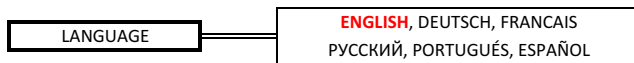

○CAMERA RESET(SETUP MENU)



OSD factory settings

■ LENS

Name	Default setting
LENS	MANUAL

■ SHUTTER/AGC

Name	Default setting
SHUTTER/AGC	AUTO
MODE	SHUT
AE LEVEL (HIGH LUMINANCE)	*Vary depending on the fine adjustment at factory
AGC	ON
AE LEVEL (LOW LUMINANCE)	x1.00

■ WHITE BAL

Name	Default setting
WHITE BAL	ATW
SPEED	128
DELAY CNT	008

■ BACKLIGHT

Name	Default setting
BACKLIGHT	OFF

■ PICT ADJUST

Name	Default setting
FLIP	OFF
BRIGHTNESS	128
CONTRAST	128
SHARPNESS	64
HUE	*Vary depending on the fine adjustment at factory
COLOR GAIN	*Vary depending on the fine adjustment at factory

■ DEFOG

Name	Default setting
DEFOG	OFF

■ WDR/ATR

Name	Default setting
WDR/ATR	OFF
BRIGHTNESS	MID
CONTRAST	MID

■ DAY/NIGHT

Name	Default setting
DAY/NIGHT	AUTO
DELAY CNT	1
DAY→NIGHT	64
NGIHT→DAY	110

■ IR LED

Name	Default setting
IR LED	AUTO
LEVEL MAX	240

■ DNR

Name	Default setting
MODE	OFF
Y LEVEL	0
C LEVEL	0

■ PRIVACY

Name	Default setting
PRIVACY	OFF

■ CAMERA ID

Name	Default setting
CAMERA ID	OFF

■ LANGUAGE

Name	Default setting
LANGUAGE	ENGLISH

5. UART Communication

5.1. Connection and electrical characteristics of communication terminals

The arrangement and electrical characteristics of the UART communication connection terminal of WAT-1100 MBD are as follows.



UART Comm. Port of the camera

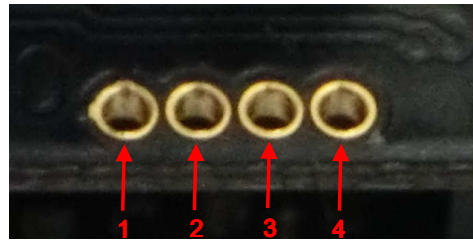

No.	Pad Name	Description
1	GND(COMMON)	COMMON GND of the camera.
2	UART TX	From the Camera to the Host communication line.
3	UART RX	From the Host to the Camera communication line.
4	POWER(+3.3V)	Camera internal digital power line.

The electrical specifications of UART TX and UART RX are as follows.

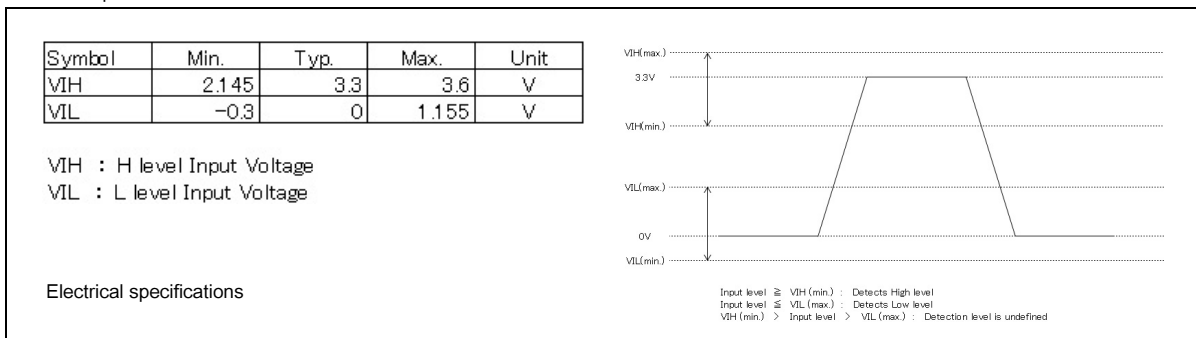

In the information on the website, since the electrical specification of the unknown.

When the electrical specification of the serial port of the Host is not the DC+3.3V interface, the level converters may be required for the communication line between the camera and Host.

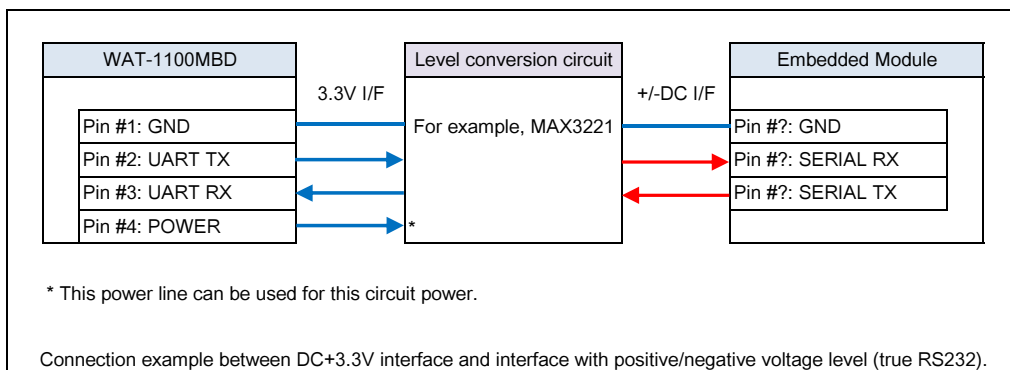
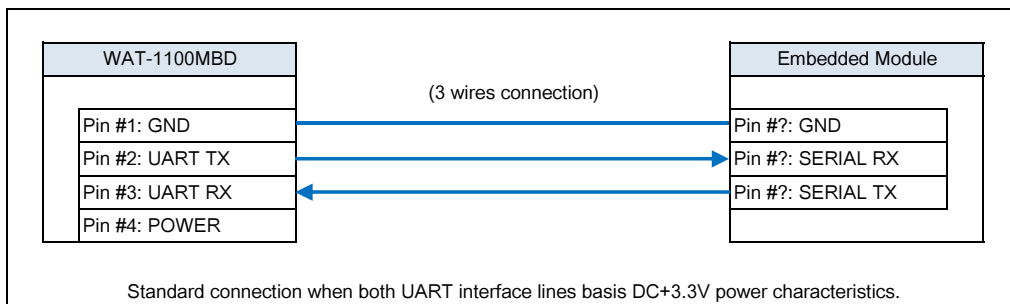

5.2. Communication specification

Communication settings of the serial line (UART) are as follows.

Baudrate	115200bps
Data length	8bit
Parity bit	None
Stop bit	1bit
Judge Time for Receive End	278[us]

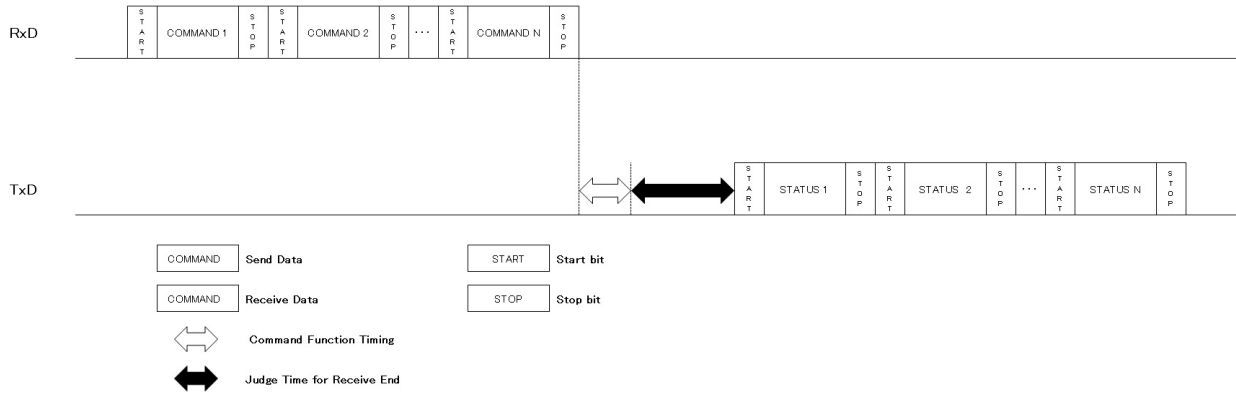

UART COMMUNICATION

UART communication sends and receives in using command formed communication protocol by packet unit.

An one packet is consist of a command to send to Camera and a status which to send to the Host microcontroller from Camera. Camera starts the command process after finished receiving the command. When the command process is finished, return the status to the Host microcontroller. The end of send data (from the Host microcontroller to Camera) will be judged from the time out. If the data communication is not occurred within the judgement period of receiving completed, Camera will judged as the end of data.

※After sending the packet, the communication is prohibited to send the next packet until receiving the status.

5.3. Packet configuration

The packet configuration is consist of concatenation of the single-command of 1 to 16.

The 1st command is data length of the packet, the 2nd command is number of the single command, the last is the checksum.

The checksum is the lower 8 bits of the SUM of the data from 0 Byte to previous of Check Sum.

The maximum number of total Byte is 137 Bytes.

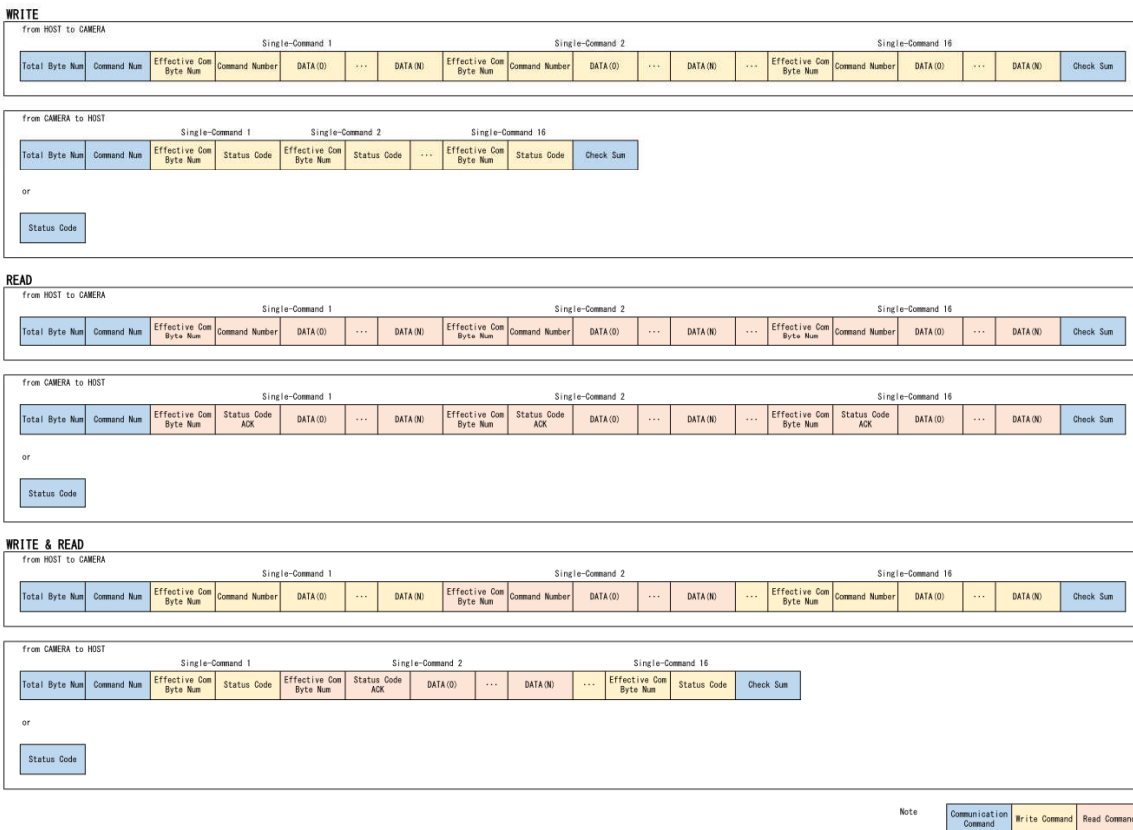

- Total Byte Num :Set the number of Byte from (Total Byte Num) to (Check Sum)
- Command Num :Set the number of Single-Command (Single-Command1,2,...),(1 ~ 16)
- Check Sum :Set the checksum from (Total Byte Num) to previous of (Check Sum)
- Status Code :Status Code *Please see the error code list.(Page 51)

COMMAND FORMAT

• Calculation example of Check Sum

FUNCTION	SET	Total Byte Num	Command Num	Single-Command 1							Single-Command 2								
				Number of Efficiency communication bytes			Command number	Category	Address offset (H)	Address offset (L)	Writing data(1)	Number of Efficiency communication bytes			Command number	Category	Address offset (H)	Address offset (L)	Writing data(1)
				Byte 1	Byte 2	Byte 3	Byte 4	Byte 5	Byte 6	Byte 7	Byte 8	Byte 9	Byte 10	Byte 11	Byte 12	Byte 13	Byte 14		
EXPOSURE CONTROL	AUTO	0x0F	0x02	0x06	0x02	0x12	0x00	0x00	0x00	0x06	0x02	0x65	0x00	0x03	0x00				

BYTE1=0F... 00001111
 BYTE2=02... 00000010
 BYTE3=06... 00000110
 BYTE4=02... 00000010
 BYTE5=12... 00010010
 BYTE9=06... 00000110
 BYTE10=02... 00000010
 BYTE11=65... 01100101
 BYTE13=03... 00000011

Check Sum **BYTE15=9B... 10011011**

○Write response (CAMERA → HOST)

FUNCTION	Total byte Num	Command Num	Single-Command 1		Single-Command 2	
			Number of Efficiency communication bytes	Status Code	Number of Efficiency communication bytes	Status Code
Write response	※1	※2	0x02	ACK ※3	0x02	ACK ※3

○Read command (HOST → CAMERA)

FUNCTION	Total byte Num	Command Num	Single-Command 1					Single-Command 2						
			Number of Efficiency communication bytes	Command number	Category	Address offset (H)	Address offset (L)	Number of Reading bytes	Number of Efficiency communication bytes	Command number	Category	Address offset (H)	Address offset (L)	Number of Reading bytes
Read command	※1	※2	0x06	0x01	※4	※4	※4	※5	0x06	0x01	※4	※4	※4	※5

○Read response (CAMERA → HOST)

FUNCTION	Total byte Num	Command Num	Single-Command 1					Single-Command 1						
			Number of Efficiency communication bytes	Status	Reading Data 1	Reading Data 2	...	Reading Data (N)	Number of Efficiency communication bytes	Status	Reading Data 1	Reading Data 2	...	Reading Data (N)
Read response	※1	※2	N + 0x02	ACK ※3	DATA 1	DATA 2		DATA N	N + 0x02	ACK ※3	DATA 1	DATA 2		DATA N

○Error code list

Incorrect Packet Value	Status Code	Description
Incorrect of the Byte number of effective communication.	0xF0	If the Byte number of necessary to command-communication and setting value are not
Incorrect of command number	0xF1	If setting the nonexistent value of command number.
Incorrect of category number	0xF2	If communicating to the nonexistent value of category number.
Incorrect of byte offset	0xF3	If communicating to the nonexistent address of the category.
Incorrect access	0xF4	If communicating to the nonexistent address in the access to the memory or Serial NOR Flash.
Command number error	0xF5	The command number of communication is either 0 or 17 or more.
Check Sum error	0xF6	Check Sum is not match.
Total Byte number error	0xF7	The number of packet data differ from total number of Byte.
SERIAL NOR FLASH access error	0xFA	SERIAL NOR FLASH access is failed.
Communication error	0xFC	The external communication is incorrect.

*1 Number of Byte from (Total Byte Num) to (Check Sum)

*2 Number of command (Command1, 2, ...). (1~16)

*3 ACK in case of successful communication, NACK in case it can not communicate.

The status of ACK is "0x01". For the status of NACK, see the error code list above.

*4 It is the same value as Write command.

*5 It is the same as N of Writing data (N).

◆WRITE COMMAND EXAMPLE

① When SHUTTER is set to MANUAL EXPOSURE

EXPOSURE CONTROL register

FUNCTION	Total byte Num	Command Num	Single-Command 1						Single-Command 2					
			Number of Efficiency communication bytes	Command number	Category	Address offset (H)	Address offset (L)	Writing data (1)	Number of Efficiency communication bytes	Command number	Category	Address offset (H)	Address offset (L)	Writing data (1)
EXPOSURE CONTROL	0x0F	0x02	0x06	0x02	0x12	0x00	0x00	0x03	0x06	0x02	0x65	0x00	0x03	0x03

1. Write command

FUNCTION	Total byte Num	Command Num	Single-Command 1						Single-Command 2						Check Sum
			Number of Efficiency communication bytes	Command number	Category	Address offset (H)	Address offset (L)	Writing data (1)	Number of Efficiency communication bytes	Command number	Category	Address offset (H)	Address offset (L)	Writing data (1)	
EXPOSURE CONTROL	0x0F	0x02	0x06	0x02	0x12	0x00	0x00	0x03	0x06	0x02	0x65	0x00	0x03	0x03	0xA1

2. Write response

FUNCTION	Total byte Num	Command Num	Single-Command 1		Single-Command 2		Check Sum
			Number of Efficiency communication bytes	Status Code	Number of Efficiency communication bytes	Status Code	
EXPOSURE CONTROL	0x07	0x02	0x02	0x01	0x02	0x01	0x0F

② When SHUTTER is set to AUTO and AGC is set to ON in one communication

Each command

FUNCTION	Total byte Num	Command Num	Single-Command 1						Single-Command 2					
			Number of Efficiency communication bytes	Command number	Category	Address offset (H)	Address offset (L)	Writing data (1)	Number of Efficiency communication bytes	Command number	Category	Address offset (H)	Address offset (L)	Writing data (1)
EXPOSURE CONTROL	0x0F	0x02	0x06	0x02	0x12	0x00	0x00	0x00	0x06	0x02	0x65	0x00	0x03	0x00
AGC	0x0F	0x02	0x06	0x02	0x13	0x00	0x99	0x00	0x06	0x02	0x65	0x00	0x0C	0x00



1. Concatenated write command

FUNCTION	Total byte Num	Command Num	Single-Command 1 (EXPOSURE CONTROL)						Single-Command 2 (EXPOSURE CONTROL)						...
			Number of Efficiency communication bytes	Command number	Category	Address offset (H)	Address offset (L)	Writing data (1)	Number of Efficiency communication bytes	Command number	Category	Address offset (H)	Address offset (L)	Writing data (1)	
EXPOSURE CONTROL & AGC	0x1B	0x04	0x06	0x02	0x12	0x00	0x00	0x00	0x06	0x02	0x65	0x00	0x03	0x00	
...			Single-Command 3 (AGC)				Single-Command 4 (AGC)				Check Sum				
			Number of Efficiency communication bytes	Command number	Category	Address offset (H)	Address offset (L)	Writing data (1)	Number of Efficiency communication bytes	Command number		Category	Address offset (H)	Address offset (L)	Writing data (1)
			0x06	0x02	0x13	0x00	0x99	0x00	0x06	0x02	0x65	0x00	0x0C	0x00	0xD6

2. Write response

FUNCTION	Total byte Num	Command Num	Single-Command 1		Single-Command 2		Single-Command 3		Single-Command 4		Check Sum
			Number of Efficiency communication bytes	Status Code	Number of Efficiency communication bytes	Status Code	Number of Efficiency communication bytes	Status Code	Number of Efficiency communication bytes	Status Code	
EXPOSURE CONTROL	0x0B	0x04	0x02	0x01	0x02	0x01	0x02	0x01	0x02	0x01	0x1B

◆ READ COMMAND EXAMPLE

① When reading EXPOSURE CONTROL

Read EXPOSURE CONTROL register

FUNCTION	Total byte Num	Command Num	Single-Command 1						Single-Command 2					
			Number of Efficiency communication bytes	Command number	Category	Address offset (H)	Address offset (L)	Number of Reading bytes	Number of Efficiency communication bytes	Command number	Category	Address offset (H)	Address offset (L)	Number of Reading bytes
Read EXPOSURE CONTROL	0x0F	0x02	0x06	0x01	0x12	0x00	0x00	0x01	0x06	0x01	0x65	0x00	0x03	0x01

1. Read command

FUNCTION	Total byte Num	Command Num	Single-Command 1						Single-Command 2						Check Sum
			Number of Efficiency communication bytes	Command number	Category	Address offset (H)	Address offset (L)	Number of Reading bytes	Number of Efficiency communication bytes	Command number	Category	Address offset (H)	Address offset (L)	Number of Reading bytes	
Read EXPOSURE CONTROL	0x0F	0x02	0x06	0x01	0x12	0x00	0x00	0x01	0x06	0x01	0x65	0x00	0x03	0x01	0x9B

2. Read response

FUNCTION	Total byte Num	Command Num	Single-Command 1			Single-Command 2			Check Sum
			Number of Efficiency communication bytes	Status	Reading Data 1	Number of Efficiency communication bytes	Status	Reading Data 1	
Read parameter	0x09	0x02	0x03	0x01	0x00	0x03	0x01	0x00	0x13

② When reading EXPOSURE CONTROL and AGC in one communication

Each read command

FUNCTION	Total byte Num	Command Num	Single-Command 1						Single-Command 2					
			Number of Efficiency communication bytes	Command number	Category	Address offset (H)	Address offset (L)	Number of Reading bytes	Number of Efficiency communication bytes	Command number	Category	Address offset (H)	Address offset (L)	Number of Reading bytes
Read EXPOSURE CONTROL	0x0F	0x02	0x06	0x01	0x12	0x00	0x00	0x01	0x06	0x01	0x65	0x00	0x03	0x01
Read AGC CONTROL	0x0F	0x02	0x06	0x01	0x13	0x00	0x99	0x01	0x06	0x01	0x65	0x00	0x0C	0x01



1. Concatenated read command

FUNCTION	Total byte Num	Command Num	Single-Command 1 (EXPOSURE CONTROL)						Single-Command 2 (EXPOSURE CONTROL)						...
			Number of Efficiency communication bytes	Command number	Category	Address offset (H)	Address offset (L)	Number of Reading bytes	Number of Efficiency communication bytes	Command number	Category	Address offset (H)	Address offset (L)	Number of Reading bytes	
Read EXPOSURE CONTROL & AGC	0x1B	0x04	0x06	0x01	0x12	0x00	0x00	0x01	0x06	0x01	0x65	0x00	0x03	0x01	
...			Single-Command 3 (AGC)			Single-Command 4 (AGC)			Check Sum						
			Number of Efficiency communication bytes	Command number	Category	Address offset (H)	Address offset (L)	Number of Reading bytes		Number of Efficiency communication bytes	Command number	Category	Address offset (H)	Address offset (L)	Number of Reading bytes
			0x06	0x01	0x13	0x00	0x99	0x01	0x06	0x01	0x65	0x00	0x0C	0x01	0xD6

2. Read response

FUNCTION	Total byte Num	Command Num	Single-Command 1			Single-Command 2			...
			Number of Efficiency communication bytes	Status	Reading Data 1	Number of Efficiency communication bytes	Status	Reading Data 1	
Read parameter	0x0F	0x04	0x03	0x01	0x00	0x03	0x01	0x00	
...			Single-Command 3			Single-Command 4			Check Sum
			Number of Efficiency communication bytes	Status	Reading Data 1	Number of Efficiency communication bytes	Status	Reading Data 1	
			0x03	0x01	0x00	0x03	0x01	0x00	0x23